

Chapter 5

Engine electrical systems

Contents

Alternator - testing	6	Electronic modules - removal and refitting	18
Alternator - removal and refitting	4	ESC Hybrid system components - removal and refitting	20
Alternator brushes - removal, inspection and refitting	7	ESC II system components - removal and refitting	19
Alternator drivebelt(s) - checking, renewal and tensioning	5	General information and precautions	1
Battery - removal and refitting	2	Ignition timing - adjustment for use with unleaded petrol	17
Battery - testing and charging	3	Ignition timing (OHC models) - adjustment	16
Coil - testing, removal and refitting	12	Starter motor - brush renewal	10
Distributor (OHC models) - removal and refitting	15	Starter motor - removal and refitting	8
Distributor cap and rotor arm (OHC models) - removal and refitting	13	Starter motor - testing in the vehicle	9
Distributor components (CVH models) - removal and refitting	14	Spark control system components - removal and refitting	22
EEC IV system components - removal and refitting	21	Spark plugs and HT leads - removal, inspection and refitting	11

Degrees of difficulty

Easy, suitable for novice with little experience 	Fairly easy, suitable for beginner with some experience 	Fairly difficult, suitable for competent DIY mechanic 	Difficult, suitable for experienced DIY mechanic 	Very difficult, suitable for expert DIY or professional 
--	---	---	--	---

Specifications

System type

1.3 litre models	Bosch inductive discharge system
1.6 litre models (except Economy)	Bosch inductive discharge system
1.6 litre Economy models	ESC system with Lucas "Hall effect" distributor
1.6 litre CVH (R6A type)	Distributorless controlled by EEC IV system
1.8 litre SOHC models	ESC II system with Bosch "Hall effect" distributor
1.8 litre CVH models	ESC Hybrid system
1.8 litre CVH (R6A type)	Distributorless controlled by EEC IV system
2.0 litre SOHC carburettor models up to 1985	Bosch inductive discharge system
2.0 litre SOHC carburettor models from 1985 (except P100)	ESC II system with Bosch "Hall effect" distributor
2.0 litre DOHC carburettor models	ESC II system
P100 models	Bosch inductive discharge system
2.0 litre SOHC fuel injection models up to 1987	EEC IV system with Motorcraft "Hall effect" distributor
2.0 litre SOHC fuel injection models from 1987	EEC IV system with Bosch "Hall effect" distributor
2.0 litre DOHC fuel injection models	EEC IV system

Coil

All models except CVH (R6A type) and 2.0 litre DOHC

Output (minimum)	25.0 kilovolts
Primary winding resistance	0.72 to 0.88 ohm
Secondary winding resistance	4500 to 7000 ohms

1.6 and 1.8 litre CVH (R6A type)

Output (minimum)	37.0 kilovolts
Primary winding resistance	0.50 ± 0.05 ohms

2.0 litre DOHC carburettor model

Output (minimum)	25.0 kilovolts
Primary winding resistance	0.72 to 0.88 ohms
Secondary winding resistance	4500 to 8600 ohms

2.0 litre DOHC fuel injection model

Output (minimum)	30.0 kilovolts
Primary winding resistance	0.72 to 0.88 ohms
Secondary resistance	4500 to 8600 ohms

Distributor

Direction of rotor arm rotation	Clockwise
Firing order	1- 3 - 4 - 2 (No 1 cylinder nearest timing cover)
Dwell angle	Automatically controlled by electronic module (not adjustable)

5•2 Engine electrical systems

Ignition timing

(at idle with vacuum pipe disconnected)

	Leaded petrol (4-star, 97 RON)	Unleaded petrol (Premium, 95 RON)
Early "Economy" models (800 rpm - vacuum pipe connected)	16° BTDC	12° BTDC
1.3 litre models	12° BTDC	8° BTDC*
1.6 litre models with VV carburettor	12° BTDC	8° BTDC*
1.6 litre models with 2V carburettor	10° BTDC	6° BTDC†
1.8 litre SOHC models	10° BTDC	6° BTDC†
1.8 litre CVH models	ESC Hybrid controlled, no adjustment possible	
2.0 litre carburettor models up to 1985	8° BTDC	4° BTDC*
2.0 litre carburettor models from 1985 (except P100)	10° BTDC	6° BTDC†
P100 models	6° BTDC	2° BTDC†
2.0 litre fuel injection models	12° BTDC	8° BTDC†

*Fill with leaded petrol (4-star, 97 RON) every 4th tankful

†Not all vehicles are suitable for continuous operation on unleaded petrol.

Spark plugs

Make and type:

All models except 1.8 CVH, CVH (R6A), 2.0 DOHC and P100	Champion RF7YCC or RF7YC
1.8 CVH engine	Champion RC7YCC or RC7YC
P100 model	Champion RF7YC or F7YC
1.6 and 1.8 CVH (R6A type) and 2.0 DOHC	Champion RC7YCC

Electrode gap:

Champion F7YCC or RC7YCC	0.8 mm (0.032 in)
Champion RF7YC, F7YC or RC7YC	0.7 mm (0.028 in)

Note: The electrode gap above is the figure quoted by Champion for use with their recommended spark plugs. If plugs of any other type are fitted, refer to their manufacturer's gap recommendations.

HT leads

All SOHC models	Champion LS-09 or LS-10 boxed set
1.8 CVH	Champion LS-10 boxed set
1.6 and 1.8 CVH (R6A type)	Champion LS-30 boxed set
2.0 DOHC	Champion LS-29 boxed set
Maximum resistance per lead	30 000 ohms

Alternator

Type	Bosch, Lucas, Motorola, or Mitsubishi
Regulated output voltage at 4000 rpm (3 to 7 amp load)	13.7 to 14.6 volts
Minimum brush length:	
All alternator types except Motorola	5.0 mm (0.20 in)
Motorola type alternators	4.0 mm (0.16 in)

Starter motor

Type	Pre-engaged; Bosch, Cajavec, Lucas, or Nippondenso
Minimum brush length:	
All except Bosch long frame 1.1 kW and JF, and Nippondenso	8.0 mm (0.32 in)
Bosch long frame 1.1 kW and JF, Nippondenso starter motors	10.0 mm (0.40 in)

Battery charge condition:

Poor	12.5 volts
Normal	12.6 volts
Good	12.7 volts

Torque wrench settings

	Nm	lbf ft
Spark plugs:		
SOHC models	20 to 28	15 to 21
CVH models	18 to 33	13 to 24
DOHC models	15 to 21	11 to 15
Crankshaft speed/position sensor clamp bolt (ESC Hybrid system)	4 to 7	3 to 5
Crankshaft speed/position sensor screw (DOHC)	3 to 5	2 to 4
Camshaft sprocket bolt (CVH models)	95 to 115	70 to 85
Air charge temperature sensor (CVH-R6A and DOHC)	20 to 25	15 to 18
Engine coolant temperature sensor (CVH-R6A and DOHC)	20 to 25	15 to 18
Fuel temperature sensor (DOHC injection)	8 to 11	6 to 8
Alternator adjustment bolt	21 to 28	15 to 20
Alternator mounting bolts:		
With coloured patch on threads	41 to 51	30 to 38
Without coloured patch	20 to 25	15 to 18

1 General information and precautions

General information

The electrical system is of the 12 volt negative earth type, and consists of a 12 volt battery, alternator with integral voltage regulator, starter motor and related electrical accessories, components and wiring. The battery is of the low maintenance or maintenance-free "sealed for life" type and is charged by an alternator which is belt-driven from the crankshaft pulley. The starter motor is of the pre-engaged type, incorporating an integral solenoid. On starting the solenoid moves the drive pinion into engagement with the flywheel ring gear before the starter motor is energised. Once the engine has started, a one-way clutch prevents the motor armature being driven by the engine until the pinion disengages from the flywheel.

The ignition system is responsible for igniting the air/fuel mixture in each cylinder at the correct moment in relation to engine speed and load. A number of different ignition systems are fitted to models within the Sierra/P100 range, ranging from a basic breakerless electronic system to a fully integrated engine management system controlling ignition and fuel injection systems.

The ignition system is based on feeding low tension voltage from the battery to the coil where it is converted to high tension voltage. The high tension voltage is powerful enough to jump the spark plug gap in the cylinders many times a second under high compression pressures, providing that the system is in good condition. The low tension (or primary) circuit consists of the battery, the lead to the ignition switch, the lead from the ignition switch to the low tension coil windings (terminal + /15) and also to the supply terminal on the electronic module, and the lead from the low tension coil windings (terminal - /1) to the control terminal on the electronic module. The high tension (or secondary) circuit consists of the high tension coil windings, the HT (high tension) lead from the coil to the distributor cap, the rotor arm, the HT leads to the spark plugs, and the spark plugs.

The system functions in the following manner. Current flowing through the low tension coil windings produces a magnetic field around the high tension windings. As the engine rotates, a sensor produces an electrical impulse which is amplified in the electronic module and used to switch off the low tension circuit.

The subsequent collapse of the magnetic field over the high tension windings produces high tension voltage which is then fed to the relevant spark plug via the distributor cap and rotor arm. The low tension circuit is automatically switched on again by the electronic module, to allow the magnetic field to build up again before the firing of the next spark plug. The ignition is advanced and retarded automatically to ensure that the

spark occurs at the correct instant in relation to the engine speed and load.

To improve driveability during warm-up conditions and to reduce exhaust emission levels, a vacuum-operated, temperature-sensitive spark control system is fitted to certain vehicles.

Inductive discharge system

This is the least sophisticated system fitted to the Sierra/P100 range, and comprises a breakerless distributor and an electronic switching/amplifier module in addition to the coil and spark plugs.

The electrical impulse which is required to switch off the low tension circuit is generated by a magnetic trigger coil in the distributor. A trigger wheel rotates within a magnetic stator, the magnetic field being provided by a permanent magnet. The magnetic field across the two poles (stator arm and trigger wheel) is dependent on the air gap between the two poles. When the air gap is at its minimum, the trigger wheel arm is directly opposite the stator arm, and this is the trigger point. As the magnetic flux between the stator arm and trigger wheel varies, a voltage is induced in the trigger coil mounted below the trigger wheel, and this voltage is sensed and then amplified by the electronic module and used to switch off the low tension circuit. There is one trigger wheel arm and one stator arm for each cylinder (4).

The ignition advance is a function of the distributor and is controlled both mechanically and by a vacuum operated system. The mechanical governor mechanism consists of two weights which move out from the distributor shaft as the engine speed rises due to centrifugal force. As they move outwards, they rotate the trigger wheel relative to the distributor shaft and so advance the spark. The weights are held in position by two light springs and it is the tension of the springs which is largely responsible for correct spark advancement.

The vacuum control consists of a diaphragm, one side of which is connected via a small bore hose to the carburettor or inlet manifold and the other side to the distributor. Depression in the inlet manifold and/or carburettor, which varies with engine speed and throttle position, causes the diaphragm to move, so moving the baseplate and advancing or retarding the spark. A fine degree of control is achieved by a spring in the diaphragm assembly.

ESC (Electronic Spark Control) system

This system is only fitted to early "Economy" models, and comprises a "Hall effect" distributor, and an ESC module, in addition to the coil and spark plugs.

The electrical impulse which is required to switch off the low tension circuit is generated by a sensor in the distributor. A trigger vane rotates in the gap between a permanent magnet and the sensor. The trigger vane has four cut-outs, one for each cylinder. When one of the trigger vane cut-outs is in line with the sensor, magnetic flux can pass between

the magnet and the sensor. When a trigger vane segment is in line with the sensor, the magnetic flux is diverted through the trigger vane away from the sensor. The sensor senses the change in magnetic flux and sends an impulse to the ESC module, which switches off the low tension circuit.

The ignition advance is a function of the ESC module and is controlled by vacuum. The module is connected to the inlet manifold by a vacuum pipe, and a transducer in the module translates the vacuum signal into electrical voltage. From the vacuum signal, the ESC module determines engine load, and engine speed is determined from the interval between impulses supplied by the distributor sensor. The module has a range of spark advance settings stored in its memory, and a suitable setting is selected for the relevant engine speed and load. The degree of advance can thus be constantly varied to suit the prevailing engine speed and load conditions.

ESC II (Electronic Spark Control II) system

1.8 and 2.0 litre SOHC carburettor models

This system is a development of the ESC system described previously in this Section, but it enables more accurate control of engine operation due to the inclusion of additional monitoring features and control outputs.

Vehicles fitted with the ESC II system have an electric inlet manifold heater which warms the air/fuel mixture when the engine is cold, thus reducing the amount of fuel enrichment required, lowering fuel consumption and improving driveability when the engine is cold. The heater is operated by the ESC II module receiving information on the engine temperature from an engine coolant temperature sensor mounted in the inlet manifold.

On 2.0 litre SOHC models, the ESC II module operates a carburettor stepper motor to control the engine idle speed. Using information on engine speed, load, temperature and throttle position (supplied by a switch on the carburettor), the module operates the stepper motor to maintain a constant idle speed. On models equipped with automatic transmission and/or air conditioning, additional inputs are supplied to the module to allow it to operate the stepper motor to compensate for the additional engine load imposed by the automatic transmission/air conditioning. The ESC II module also operates a "power hold" relay which allows the stepper motor to function briefly after the ignition has been switched off in order to perform an anti-run-on and manifold ventilation cycle.

2.0 litre DOHC carburettor models

A development of the ESC II system is used to control the operation of the engine. The module receives information from a crankshaft speed/position sensor (similar to that described for the ESC Hybrid system), except that the sensor is activated by a toothed disc on the rear of the crankshaft, inside the cylinder block), and an engine coolant temperature sensor.

5•4 Engine electrical systems

The ignition advance is a function of the ESC II module, and is controlled by vacuum. The module is connected to the carburettor by a vacuum pipe, and a transducer in the module translates the vacuum signal into an electrical voltage. From the vacuum signal, the module determines engine load; engine speed and temperature are determined from the crankshaft speed/position sensor and the engine coolant temperature sensor. The module has a range of spark advance settings stored in its memory, and a suitable setting is selected for the relevant engine speed, load and temperature. The degree of advance can thus be constantly varied to suit the prevailing engine speed and load conditions.

ESC Hybrid (Electronic Spark Control Hybrid) system

This system is fitted to 1.8 CVH models, and comprises various sensors and an ESC Hybrid module, in addition to the coil and spark plugs. The distributor serves purely to distribute the HT voltage to the spark plugs and consists simply of a rotor arm mounted directly on the end of the camshaft, and a distributor cap.

The electrical impulse which is required to switch off the low tension circuit is generated by a crankshaft speed/position sensor which is activated by a toothed wheel on the crankshaft. The toothed wheel has 35 equally spaced teeth with a gap in the 36th position. The gap is used by the sensor to determine the crankshaft position relative to TDC (top dead centre) of No 1 piston.

Engine load information is supplied to the ESC Hybrid module by a vacuum transducer within the module which is connected to the inlet manifold by a vacuum pipe. Additional inputs are supplied by an inlet manifold-mounted engine coolant temperature sensor, and an air charge temperature sensor mounted in the base of the air cleaner. The module selects the optimum ignition advance setting based on the information received from the various sensors. The degree of advance can thus be constantly varied to suit the prevailing engine conditions.

In addition to the ignition circuit, the module also controls an electric choke heater, and a solenoid valve which in turn controls a throttle damper on the carburettor. The electric choke heater is operated by the module using information supplied by the engine coolant temperature sensor. The heater is used to slow down the rate at which the choke comes off, thereby improving driveability and overall fuel consumption when the engine is cold. The solenoid valve controls the vacuum supply to the carburettor throttle damper. The throttle damper prevents sudden closing of the throttle during deceleration, thus maintaining combustion of the air/fuel mixture which reduces harmful exhaust gas emissions.

Note that there is no provision for adjustment of ignition timing with the ESC Hybrid system.

EEC IV (Electronic Engine Control IV) system

2.0 litre SOHC fuel injection models

This system controls both the ignition and fuel injection systems. The EEC IV module receives information from a "Hall effect" distributor sensor (similar to that described previously in this Section for the ESC system), an engine coolant temperature sensor mounted in the inlet manifold, a throttle position sensor, and an air flow meter.

Additionally, on models equipped with automatic transmission and/or air conditioning, additional inputs are supplied to the module to allow it to raise the idle speed to compensate for the additional engine load imposed by the automatic transmission/air conditioning. The module provides outputs to control the fuel pump, fuel injectors, idle speed, and ignition circuit. Using the inputs from the various sensors, the EEC IV module computes the optimum ignition advance, and fuel injector pulse duration to suit the prevailing engine conditions. This system gives very accurate control of the engine under all conditions, improving fuel consumption and driveability, and reducing exhaust gas emissions. A "limited operation strategy" (LOS) means that the vehicle is still driveable, albeit at reduced power and efficiency, in the event of a failure in the module or its sensors.

2.0 litre DOHC fuel injection models

A development of the EEC IV system is used to control both the ignition and fuel injection systems. The module receives information from a crankshaft speed/position sensor (similar to that described for the ESC Hybrid system), except that the sensor is activated by a toothed disc on the rear of the crankshaft, inside the cylinder block), a throttle position sensor, an engine coolant temperature sensor, a fuel temperature sensor, an air charge temperature sensor, a manifold absolute pressure (MAP) sensor, and a vehicle speed sensor (mounted on the gearbox). Additionally, on models with a catalytic converter, an additional input is supplied to the EEC IV module from an exhaust gas oxygen (HEGO) sensor. On models with automatic transmission, additional sensors are fitted to the transmission, to inform the EEC IV module when the transmission is in neutral, and when the kickdown is being operated.

The module provides outputs to control the fuel pump, fuel injectors, idle speed, ignition system and automatic transmission. Additionally, on models with air conditioning, the EEC IV module disengages the air conditioning compressor clutch when starting the engine, and when the engine is suddenly accelerated. On models fitted with a catalytic converter, the EEC IV module also controls the carbon canister-purge solenoid valve.

Using the inputs from the various sensors, the EEC IV module computes the optimum ignition advance, and fuel injector pulse duration to suit the prevailing engine conditions. A "limited operation strategy" (LOS)

means that the vehicle is still driveable, albeit at reduced power and efficiency, in the event of a failure in the module or one of its sensors.

1.6 litre and 1.8 litre (R6A type) CVH models

A development of the EEC IV system is used to control both the ignition and fuel injection systems. A fully electronic Distributorless Ignition System (DIS) is fitted, replacing the mechanical distribution of high tension voltage (by a rotating distributor) with "static" solid-state electronic components.

The system selects the most appropriate ignition advance setting for the prevailing engine operating conditions from a three-dimensional map of values stored in the EEC IV control module memory. The module selects the appropriate advance value according to information supplied on engine load, speed, and operating temperature from various sensors.

The EEC IV module receives information from a crankshaft speed/position sensor (similar to that described for the ESC Hybrid system), except that on 1.6 litre engines, the sensor is activated by a toothed disc on the flywheel), a throttle position sensor, an engine coolant temperature sensor, an air charge temperature sensor, a manifold absolute pressure (MAP) sensor, a vehicle speed sensor (mounted on the gearbox), and an exhaust gas oxygen sensor.

The module provides outputs to control the fuel pump, fuel injector, throttle valve control motor, pulse-air control solenoid, carbon canister purge solenoid (where applicable), and the ignition system.

Using the inputs from the various sensors, the EEC IV module computes the optimum ignition advance and fuel injector pulse duration to suit the prevailing engine conditions. A "limited operation strategy" (LOS) means that the vehicle will still be driveable, albeit at reduced power and efficiency, in the event of a failure in the module or one of its sensors.

Precautions

General

It is necessary to take extra care when working on the electrical system to avoid damage to semi-conductor devices (diodes and transistors), and to avoid the risk of personal injury. In addition to the precautions given in the "Safety first!" Section at the beginning of this manual, take note of the following points when working on the system.

Always remove rings, watches, etc before working on the electrical system. Even with the battery disconnected, capacitive discharge could occur if a component live terminal is earthed through a metal object. This could cause a shock or nasty burn.

Do not reverse the battery connections. Components such as the alternator or any other having semi-conductor circuitry could be irreparably damaged.

If the engine is being started using jump leads and a slave battery, connect the batteries positive to positive and negative to negative. This also applies when connecting a battery charger.

Never disconnect the battery terminals, or alternator multi-plug connector, when the engine is running.

The battery leads and alternator multi-plug must be disconnected before carrying out any electric welding on the car.

Never use an ohmmeter of the type incorporating a hand cranked generator for circuit or continuity testing.

Ignition and engine management systems



Warning: The HT voltage generated by an electronic ignition system is extremely high, and in certain

circumstances could prove fatal. Take care to avoid receiving electric shocks from the HT side of the ignition system. Do not handle HT leads, or touch the distributor or coil when the engine is running. If tracing faults in the HT circuit, use well insulated tools to manipulate live leads.

Engine management modules are very sensitive components, and certain precautions must be taken to avoid damage to the module when working on a vehicle equipped with an engine management system as follows.

When carrying out welding operations on the vehicle using electric welding equipment, the battery and alternator should be disconnected.

Although underbonnet-mounted modules (all except EEC IV) will tolerate normal underbonnet conditions, they can be adversely affected by excess heat or moisture. If using welding equipment or pressure washing equipment in the vicinity of the module, take care not to direct heat, or jets of water or steam at the module. If this cannot be avoided, remove the module from the vehicle, and protect its wiring plug with a plastic bag.

Before disconnecting any wiring, or removing components, always ensure that the ignition is switched off.

On models with underbonnet-mounted modules, do not run the engine with the module detached from the body panel, as the body acts as an effective heat sink, and the module may be damaged due to internal overheating.

Do not attempt to improvise fault diagnosis procedures using a test lamp or multimeter, as irreparable damage could be caused to the module.

After working on ignition/engine management system components, ensure that all wiring is correctly reconnected before reconnecting the battery or switching on the ignition.

On some early Bosch distributors it is possible that with the distributor cap removed, if the engine is cranked, the cap securing clips may fall inward and jam the trigger wheel/vane, knocking it out of alignment. If this happens, the distributor will have to be renewed as the trigger wheel/vane cannot be repositioned. Care should therefore be taken not to crank the engine with the distributor cap removed. Later distributors have redesigned clips which eliminate the problem.

2 Battery - removal and refitting



Removal

1 The battery is located in the engine compartment on the left-hand side of the bulkhead.

2 Disconnect the leads at the negative (earth) terminal by unscrewing the retaining nut and removing the bulb. Pull off the plastic cover, and disconnect the positive terminal leads in the same way.

3 Unscrew the clamp bolt sufficiently to enable the battery to be lifted from its location (see illustration). Keep the battery in an upright position to avoid spilling electrolyte on the bodywork.

Refitting

4 Refitting is a reversal of removal, but smear petroleum jelly on the terminals when reconnecting the leads, and always connect the positive lead first and the negative lead last.

3 Battery - testing and charging



Testing

Standard and low maintenance battery

1 If the vehicle covers a small annual mileage it is worthwhile checking the specific gravity of the electrolyte every three months to determine the state of charge of the battery. Use a hydrometer to make the check and compare the results with the following table.

Ambient temperature:

	above 25°C	below 25°C
Fully charged	1.21 to 1.23	1.27 to 1.29
70% charged	1.17 to 1.19	1.23 to 1.25
Fully discharged	1.05 to 1.07	1.11 to 1.13

Note that the specific gravity readings assume an electrolyte temperature of 15°C (60°F); for every 10°C (50°F) below 15°C (60°F) subtract 0.007. For every 10°C (50°F) above 15°C (60°F) add 0.007.

2 If the battery condition is suspect first check the specific gravity of electrolyte in each cell. A variation of 0.040 or more between any cells indicates loss of electrolyte or deterioration of the internal plates.

3 If the specific gravity variation is 0.040 or more, the battery should be renewed. If the cell variation is satisfactory but the battery is discharged, it should be charged as described later in this Section.

Maintenance-free battery

4 In cases where a "sealed-for-life" maintenance-free battery is fitted, topping-up and testing of the electrolyte in each cell is not possible. The condition of the battery can therefore only be tested using a battery condition indicator or a voltmeter.

5 If testing the battery using a voltmeter, connect the voltmeter across the battery and compare the result with those given in the

Specifications under "charge condition". The test is only accurate if the battery has not been subject to any kind of charge for the previous six hours. If this is not the case, switch on the headlights for 30 seconds, then wait four to five minutes before testing the battery after switching off the headlights. All other electrical components must be switched off, so check that the doors and tailgate are fully shut when making the test.

6 If the voltage reading is less than 12.2 volts, then the battery is discharged, whilst a reading of 12.2 to 12.4 volts indicates a partially discharged condition.

7 If the battery is to be charged, first remove it from the vehicle.

Charging

Standard and low maintenance battery

8 Charge the battery at a rate of 3.5 to 4 amps and continue to charge the battery at this rate until no further rise in specific gravity is noted over a four hour period.

9 Alternatively, a trickle charger charging at the rate of 1.5 amps can be safely used overnight.

10 Specially rapid "boost" charges which are claimed to restore the power of the battery in 1 to 2 hours are not recommended as they can cause serious damage to the battery plates through overheating.

11 While charging the battery, note that the temperature of the electrolyte should never exceed 37.8°C (100°F).

Maintenance-free battery

12 This battery type takes considerably longer to fully recharge than the standard type, the time taken being dependent on the extent of discharge, but it can take anything up to three days.

13 A constant voltage type charger is required, to be set, when connected, to 13.9 to 14.9 volts with a charger current below 25 amps. Using this method the battery should be useable within three hours, giving a voltage reading of 12.5 volts, but this is for a partially discharged battery and, as mentioned, full charging can take considerably longer.

14 If the battery is to be charged from a fully discharged state (condition reading less than 12.2 volts) have it recharged by your Ford dealer or local automotive electrician as the charge rate is higher and constant supervision during charging is necessary.



2.3 Battery securing clamp and bolt



4.2a Disconnecting the multi-plug from a Bosch alternator

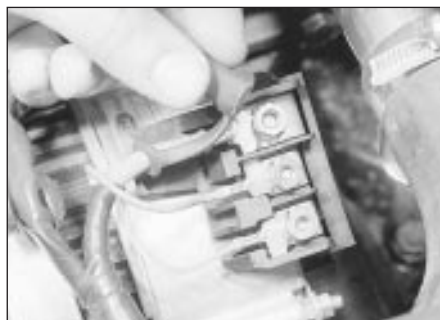

4.2b Removing the insulating cap from the main wiring terminal on a Lucas A127 alternator (CVH model)

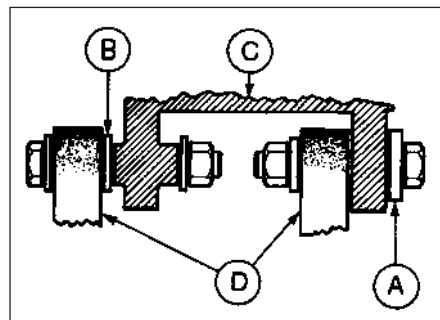

4.7 Alternator mounting bracket arrangement

- A Large flat washer
- B Small flat washer (models up to 1985 only)
- C Mounting bracket (engine)
- D Mounting lugs (alternator)

4 Alternator - removal and refitting

Removal

- 1 Disconnect the battery leads.
- 2 Disconnect the multi-plug, or disconnect the wires from their terminals on the rear of the alternator, noting their locations (as applicable), then slacken the mounting and adjustment bolts and tilt the alternator towards the engine (see illustrations).
- 3 Remove the drivebelt(s) from the alternator pulley(s).
- 4 Remove the mounting and adjustment nuts and bolts, and withdraw the alternator from the engine.

Refitting

- 5 Refitting is a reversal of removal, noting the following points.
- 6 To avoid breakage of the alternator mounting bracket lugs, it is important that the following procedure is adhered to when refitting the mounting bolts.
- 7 Always refit the large flat washer (A) (see illustration).
- 8 Earlier models (before 1985) also have a small washer (B) which must be fitted between the sliding bush and the mounting bracket.
- 9 Ensure that the bushes and bolts are assembled as shown - except on 2.0 litre DOHC models where a through-bolt is used, then tension the drivebelt(s) and tighten the mounting and adjustment bolts as shown in the relevant illustration in Chapter 3.

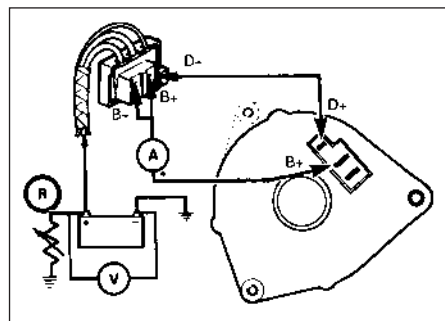

6.5 Alternator output test circuit

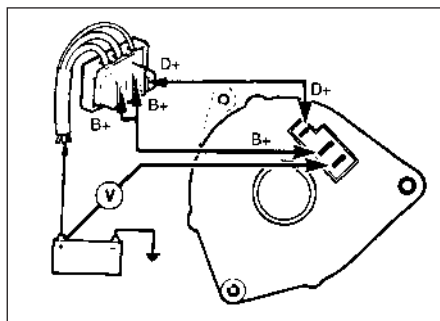

6.6 Alternator positive check circuit

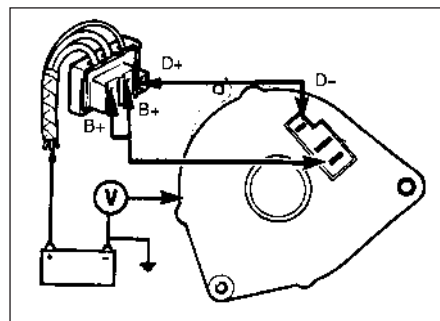

6.7 Alternator negative check circuit

5 Alternator drivebelt(s) - checking, renewal and tensioning

Refer to Chapter 1, Section 21.

6 Alternator - testing

Note: To carry out the complete test procedure use only the following test equipment - a 0 to 20 volt moving coil voltmeter, a 0 to 100 amp moving coil ammeter, and a rheostat rated at 30 amps.

- 1 Check that the battery is at least 70% charged by using a hydrometer.
- 2 Check the drivebelt tension.
- 3 Check the security of the battery leads, alternator multi-plug, and interconnecting wire.

Cable continuity check

- 4 Pull the multi-plug from the alternator and switch on the ignition, being careful not to crank the engine. Connect the voltmeter between a good earth and each of the terminals in the multi-plug in turn. If battery voltage is not indicated, there is an open circuit in the wiring which may be due to a blown ignition warning light bulb if on the small terminal.

Alternator output check

- 5 Connect the voltmeter, ammeter and rheostat as shown (see illustration). Run the engine at 3000 rpm and switch on the headlamps, heater blower and, where fitted, the heated rear window. Vary the resistance

to increase the current and check that the alternator rated output is reached without the voltage dropping below 13 volts.

Charging circuit positive side check

- 6 Connect the voltmeter as shown (see illustration). Start the engine and switch on the headlamps. Run the engine at 3000 rpm and check that the indicated voltage drop does not exceed 0.5 volt. A higher reading indicates a high resistance such as a dirty connection on the positive side of the charging circuit.

Charging circuit negative side check

- 7 Connect the voltmeter as shown (see illustration). Start the engine and switch on the headlamps. Run the engine at 3000 rpm and check that the indicated voltage drop does not exceed 0.25 volt. A higher reading indicates a high resistance such as a dirty connection on the negative side of the charging circuit.

Voltage regulator check

- 8 Connect the voltmeter and ammeter as shown (see illustration). Run the engine at 3000 rpm and when the ammeter records a current of 3 to 5 amps check that the voltmeter records 13.7 to 14.15 volts. If the result is outside the limits the regulator is faulty.

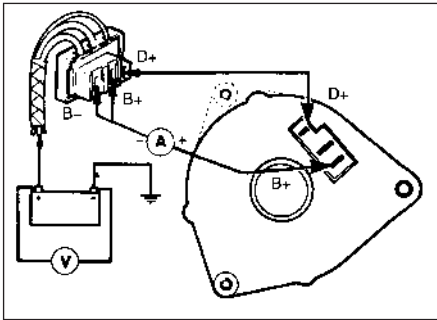

6.8 Alternator voltage regulator test circuit

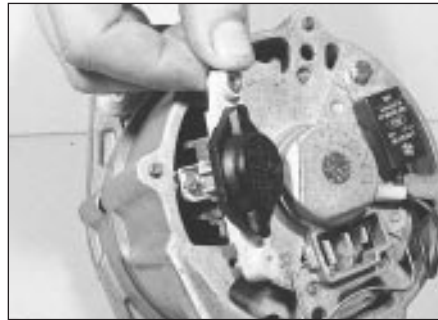

7.2 Withdrawing the regulator/brush box from a Bosch alternator

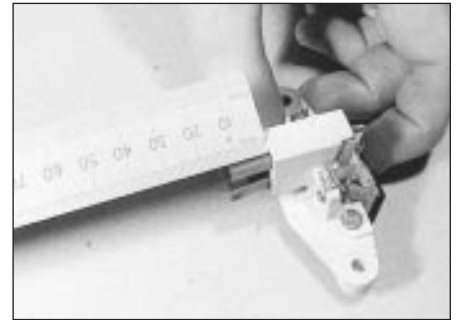

7.3 Compare the brush length with the figure in the Specifications - Bosch alternator

7 Alternator brushes - removal, inspection and refitting



1 Remove the alternator.

Bosch type

2 Remove the two securing screws and withdraw the regulator/brush box assembly from the rear of the alternator (see illustration).

3 If the length of either brush is less than the minimum given in the Specifications, unsolder the wiring and remove the brushes and the springs (see illustration).

4 Wipe the slip rings clean with a fuel-moistened cloth. If the rings are very dirty use fine glasspaper to clean them, then wipe with the cloth (see illustration).



7.4 Inspect the condition of the slip rings (arrowed) - Bosch alternator



7.13 Removing the terminal cover from a Lucas A127 alternator.

5 Refitting is a reversal of removal, but make sure that the brushes move freely in their holders.

Lucas A 115 and A 133 type

6 Disconnect the wiring plug, then remove the securing screw and withdraw the interference suppression capacitor from the rear cover.

7 Extract the two securing screws and remove the alternator rear cover.

8 Make a careful note of the fitted positions of the regulator wires, then disconnect the wires from the diode pack and the brush box.

9 Remove the regulator securing screws and withdraw the regulator. Note that the regulator securing screw also holds one of the brush mounting plates in position.

10 Remove the two securing screws and withdraw the brush box. Remove the securing

screws and lift the brushes from the brush box.

11 If the length of either brush is less than the minimum given in the Specifications, renew both brushes.

12 Proceed as shown in paragraphs 4 and 5.

Lucas A 127 type

13 Where applicable, for improved access remove the terminal cover from the rear of the alternator, then remove the three screws securing the regulator/brush box assembly to the rear of the alternator (see illustration).

14 Tip the outside edge of the assembly upwards, and withdraw it from its location. Disconnect the wiring plug and withdraw the assembly from the alternator (see illustration).

15 If the length of either brush is less than the minimum given in the Specifications, the complete regulator/brush box assembly must be renewed (see illustration).

16 Proceed as described in paragraphs 4 and 5 (see illustration).

Motorola type

17 Remove the two securing screws and withdraw the regulator. Disconnect the regulator wires after noting their locations.

18 Remove the single securing screw (35 and 45 amp types) or two securing screws (55 and 70 amp types) and carefully withdraw the brush box.

19 If the length of either brush is less than the minimum given in the Specifications, the brush box must be renewed.

20 Proceed as shown in paragraphs 4 and 5.



7.14 Disconnect the wiring plug and withdraw the regulator/brushbox - Lucas A127 alternator



7.15 Compare the brush length with the figure given in the Specifications - Lucas A127 alternator



7.16 Inspect the condition of the slip rings (arrowed) - Lucas A127 alternator

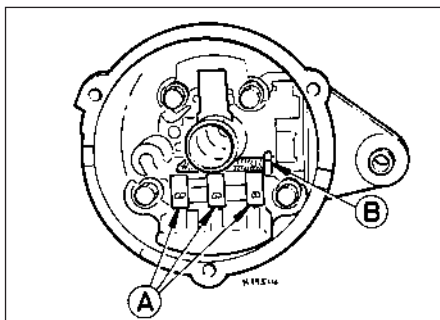

7.28 Stator-to-diode pack connections (A) and brushbox-to-diode pack terminal (B) - Mitsubishi alternator

Mitsubishi type

- 21 Unscrew the pulley nut. To prevent the shaft rotating, insert an Allen key in the end of the shaft.
- 22 Remove the spring washer, pulley, fan, spacer and dust shield.
- 23 Scribe an alignment mark along the length of the alternator to facilitate reassembly of the drive end housing, stator and rear housing.
- 24 Unscrew the through-bolts and withdraw the drive end housing from the rotor shaft.
- 25 Remove the seal and spacer from the rotor shaft.
- 26 Remove the rotor from the rear housing and the stator. This may require the application of local heat to the rear housing using a large soldering iron. Do not use a heat gun, as this may result in damage to the diodes.
- 27 Unscrew the four securing bolts and withdraw the diode pack stator assembly from the rear housing.
- 28 Unsolder the stator leads from the diode pack terminals. Use a pair of pliers when unsoldering to act as a heat sink, otherwise damage to the diodes may occur (see illustration).
- 29 If the length of either brush is less than the minimum given in the Specifications, the brush box must be renewed.
- 30 To renew the brush box, unsolder the connection to the diode pack, and solder the



8.3 Solenoid wiring connections on Lucas M79 starter motor- CVH engine

- connection to the new brush box. Use a pair of pliers as a heat sink to avoid damage to the diodes.
- 31 Examine the surfaces of the slip rings. Clean them with a fuel moistened cloth, or if necessary fine glasspaper and then the cloth.
- 32 Solder the stator leads to the diode pack terminals, again using a pair of pliers as a heat sink.
- 33 Refit the diode pack/stator assembly to the rear housing and tighten the securing bolts.
- 34 Insert a thin rod (an Allen key is ideal) through the hole in the rear housing to hold the brushes in the retracted position.
- 35 Fit the rotor to the rear housing and then remove the temporary rod to release the brushes.
- 36 Reassemble the remaining components by reversing the dismantling operations. Make sure that the scribed marks are in alignment.

8 Starter motor - removal and refitting

Removal

- 1 Apply the handbrake, jack up the front of the vehicle and support on axle stands (see "Jacking and Vehicle Support").
- 2 Disconnect the battery negative lead.
- 3 Working underneath the vehicle, unscrew



8.5 Unscrew the starter motor mounting bolts

- the nut and disconnect the main cable from the starter solenoid (see illustration).
- 4 Disconnect the ignition switch wire from the solenoid.
- 5 Unscrew the three mounting bolts and withdraw the starter motor from the gearbox bellhousing (see illustration).

Refitting

- 6 Refitting is a reversal of removal.

9 Starter motor - testing in the vehicle

- 1 If the starter motor fails to operate first check the condition of the battery.
- 2 Check the security and condition of all relevant wiring.

Solenoid check

- 3 Disconnect the battery negative lead and all leads from the solenoid.
- 4 Connect a 3 watt test lamp and a 12 volt battery between the starter terminal on the solenoid and the solenoid body as shown (see illustration). The testlamp should light. If not, there is an open circuit in the solenoid windings.
- 5 Now connect an 18 watt testlamp between both solenoid terminals (see illustration), then energise the solenoid with a further lead to the spade terminal. The solenoid should be heard to operate and the testlamp should light. Reconnect the solenoid wires.

On load voltage check

- 6 Connect a voltmeter across the battery terminals, then disconnect the low tension lead from the coil positive terminal and operate the starter by turning the ignition switch. Note the reading on the voltmeter which should not be less than 10.5 volts.
- 7 Now connect the voltmeter between the starter motor terminal on the solenoid and the starter motor body. With the coil low tension lead still disconnected operate the starter and check that the recorded voltage is not more than 1 volt lower than that noted in paragraph 6. If the voltage drop is more than 1 volt a fault exists in the wiring from the battery to the starter.

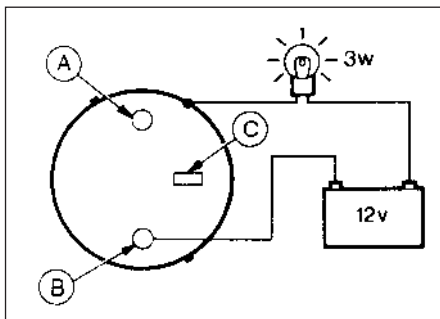

9.4 Starter motor solenoid winding test circuit

- A Battery terminal
- B Motor terminal
- C Spade terminal

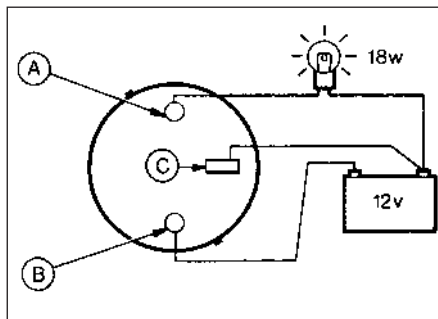

9.5 Starter motor solenoid continuity test circuit

- A Battery terminal
- B Motor terminal
- C Spade terminal

8 Connect the voltmeter between the battery positive terminal and the terminal on the starter motor. With the coil low tension lead disconnected operate the starter for two or three seconds. Battery voltage should be indicated initially, then dropping to less than 1 volt. If the reading is more than 1 volt, there is a high resistance in the wiring from the battery to the starter and the check in paragraph 9 should be made. If the reading is less than 1 volt proceed to paragraph 10.

9 Connect the voltmeter between the two main solenoid terminals and operate the starter for two or three seconds. Battery voltage should be indicated initially, then dropping to less than 0.5 volt. If the reading is more than 0.5 volt, the ignition switch and connections may be faulty.

10 Connect the voltmeter between the battery negative terminal and the starter motor body, and operate the starter for two or three seconds. A reading of less than 0.5 volt should be recorded. If the reading is more than 0.5 volt, there is a fault in the earth circuit, and the earth connections to the battery and body should be checked.

10 Starter motor - brush renewal

Bosch long frame and JF, and Cajavec types

1 With the starter motor removed from the vehicle and cleaned, grip the unit in a vice fitted with soft jaw protectors.

2 Remove the two screws securing the commutator end housing cap, then remove the cap and rubber seal (see illustration).

3 Wipe any grease from the armature shaft, and remove the C-clip, or E-clip, as applicable, and shims from the end of the shaft (see illustrations).

4 Unscrew the two nuts and remove the washers, or remove the securing screws (as applicable), then lift off the commutator end housing (see illustrations).

5 Carefully prise the thrust retaining springs from their locations, then slide the brushes from the brush plate.

6 If the brushes have worn to less than the specified minimum, renew them as a set. To



10.2 Remove the commutator end housing cap securing screws - Bosch long frame starter motor



10.3a Remove the C-clip . . .



10.3b . . . and shims from the end of the armature shaft - Bosch long frame starter motor

Bosch short frame, EV and EF types

14 To remove and refit the brush assembly, proceed as for the Bosch long frame except for the following (see illustration):

15 Release the brush holders complete with brushes by pushing the brush holders towards the commutator and unclipping them from the brush plate. Withdraw the brush plate.

16 To renew the brushes, the leads must be unsoldered from the terminals on the brush plate, and the leads of the new brushes must be soldered to the terminals.

17 To refit the brush assembly, position the brush plate over the end of the armature shaft, then assemble the brush holders, brushes and springs, ensuring that the brush holder clips are securely located. The brush plate will be



10.4a Remove the commutator end housing securing screws - Bosch long frame starter motor



10.4b Commutator end housing removed to expose brush plate - Bosch long frame starter motor

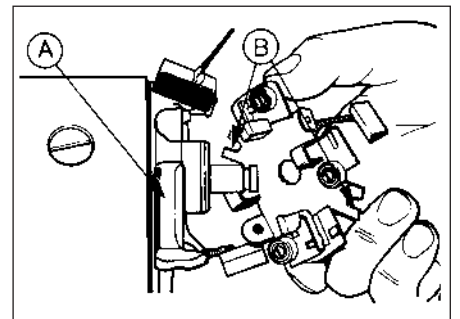

10.9 Align the cut-outs in the brush plate (B) with the loops in the field windings (A) - Bosch long frame starter motor

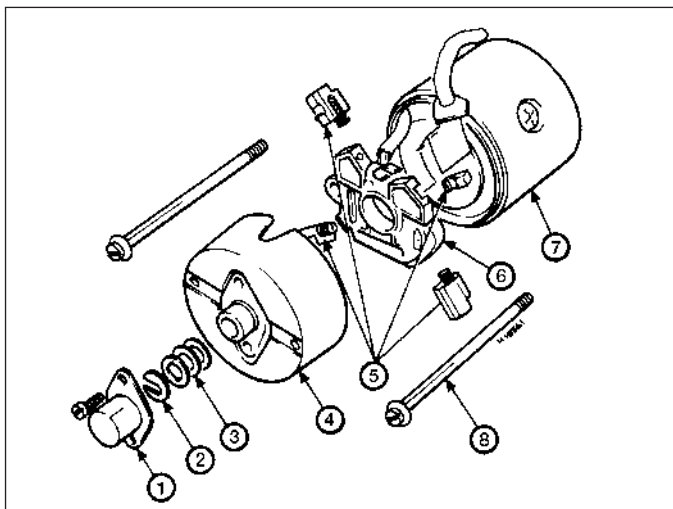

10.14 Bosch EV starter motor brush assembly

- | | |
|------------------------------|--------------------------------|
| 1 Commutator end housing cap | 5 Brushes |
| 2 C-clip | 6 Brush plate |
| 3 Shims | 7 Yoke |
| 4 Commutator end housing | 8 Commutator end housing screw |

positively located when the commutator end housing screws are fitted.

Bosch DM and DW types

18 The procedure is basically as described previously for the Bosch short frame and EF type starter motors, except that a commutator end plate is fitted in place of the end housing (see illustrations).

Lucas 5M90 type

Note: New star clips must be obtained for the armature shaft on reassembly

19 With the starter motor removed from the vehicle and cleaned, grip the unit in a vice fitted with soft jaw protectors.

20 Remove the plastic cap from the end of the armature shaft, then remove the star clip from the end of the shaft, using a chisel at an angle of 45° to the shaft to distort the prongs

of the clip until it can be removed (see illustrations).

21 Unscrew the two securing nuts and remove the connector cable from the main feed terminal (see illustration).

22 Extract the two commutator end plate securing screws, and carefully tap the end plate to free it. Lift the end plate clear to allow access to the two field brushes. Disconnect the two field brushes from the brush box to allow complete removal of the commutator end plate. Take care not to damage the gasket as the end plate is removed.

23 Remove the nut, washer and insulator from the main terminal stud on the commutator end plate, then push the stud and the second insulator through the end plate and unhook the brushes.

24 To remove the brush box, drill out the rivets securing the brush box to the end plate, then remove the brush box and gasket.

25 If the brushes have worn to less than the specified minimum, renew them as a set. To renew the brushes, cut the leads at their midpoint and make a good soldered joint when connecting the new brushes.

26 The commutator face should be clean and free from burnt spots. Where necessary burnish with fine glass paper (not emery) and wipe with a fuel-moistened cloth.

27 Commence reassembly by positioning the brush box gasket on the commutator end plate, then position the brush box on the gasket and rivet the brush box to the end plate. Use a new gasket if necessary.

28 Fit the main terminal stud and insulator to the commutator end plate, then secure the stud with the remaining insulator, washer and nut. Fit the two brushes which are attached to the terminal stud into their respective locations in the brush box.

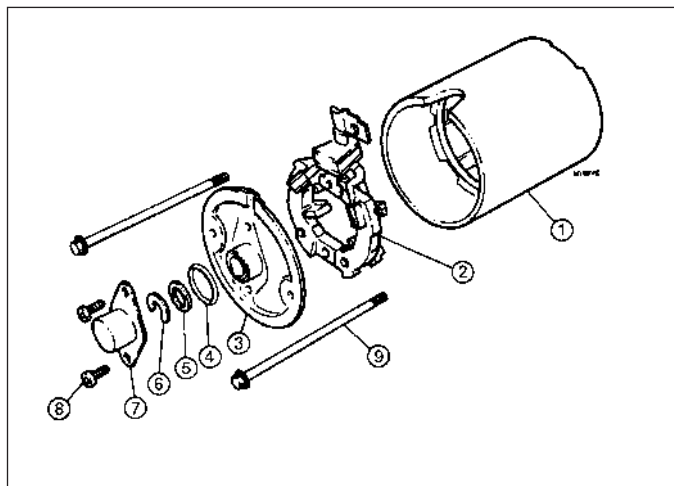

10.18a Bosch DM starter motor brush assembly

- | | |
|--------------------------|---|
| 1 Yoke | 6 C-clip |
| 2 Brush plate | 7 Commutator end housing cap |
| 3 Commutator end housing | 8 Securing screw |
| 4 Seal | 9 Commutator end housing securing screw |
| 5 Shim | |

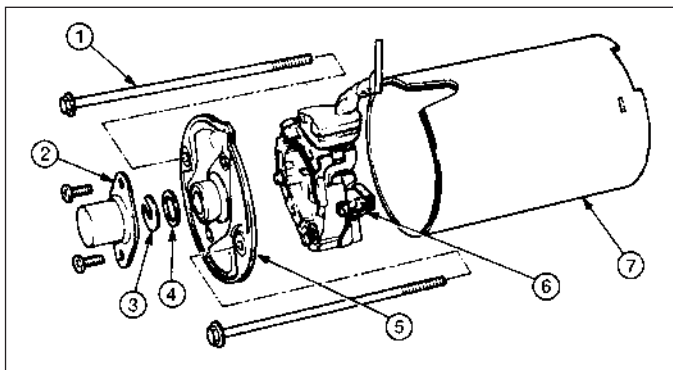

10.18b Bosch DW starter motor brush assembly

- | | |
|---------------------------------------|------------------------|
| 1 Commutator end plate securing screw | 4 Shim |
| 2 Commutator end plate cap | 5 Commutator end plate |
| 3 C-clip | 6 Brush plate |
| | 7 Yoke |



10.20a Remove the plastic cap from the end of the armature shaft . . .



10.20b . . . followed by the star clip - Lucas 5M90 starter motor

10.21 Lucas 5M90 starter motor brush assembly

- 1 Main terminal nuts and washers
- 2 Commutator end plate
- 3 Brush box
- 4 Brush spring
- 5 Brushes
- 6 Yoke
- 7 Armature
- 8 Thrustwasher
- 9 Commutator end plate securing screw
- 10 Bush
- 11 Thrustplate
- 12 Star clip
- 13 Plastic cap

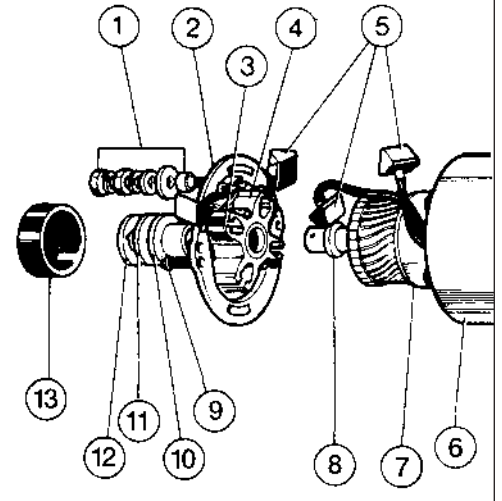

10.30 Use a soft faced hammer and socket to fit a new star clip to the end of the armature shaft - Lucas 5M90 starter motor

29 Fit the two field brushes into their locations in the brush box, then position the commutator end plate on the yoke and fit the two securing screws.

30 Fit a new star clip to the end of the armature shaft, ensuring that the clip is pressed home firmly to eliminate any endfloat in the armature (see illustration). Fit the plastic cap over the end of the armature shaft.

Lucas 8M90 type

31 The procedure is basically as described previously for the 5M90 type starter motor with the following difference (see illustration):

32 The commutator end plate is secured by two screws. The end plate and brush box are serviced as an assembly and should be renewed.

Lucas M79 type

33 With the starter motor removed from the vehicle and cleaned, grip the unit in a vice

fitted with soft jaw protectors.

34 Unscrew the securing nut and washer and disconnect the wiring from the solenoid terminal.

35 Remove the two screws securing the commutator end housing cap. Remove the cap.

36 Remove the C-clip and spacers from the end of the armature shaft.

37 Remove the two commutator end housing securing screws and withdraw the end housing.

38 Separate the brush components (see illustration).

39 If the brushes have worn to less than the specified minimum, renew them as a set. To renew the brushes, cut the leads at their midpoint and make a good soldered joint when connecting the new brushes.

40 The commutator face should be clean and free from burnt spots. Where necessary burnish with fine glass paper (not emery) and wipe with a fuel-moistened cloth.

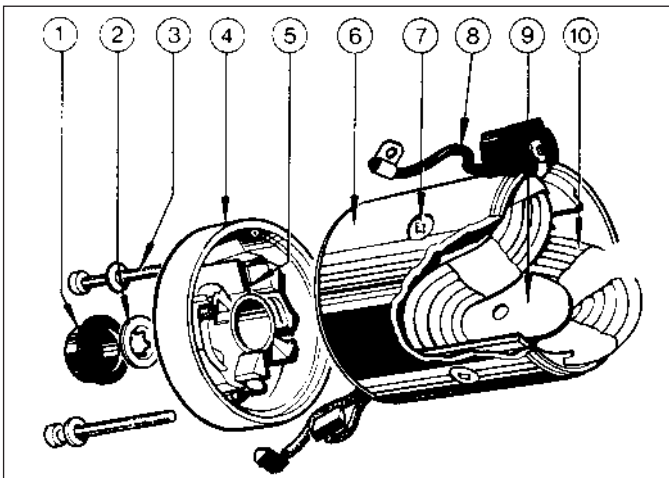

10.31 Lucas 8M90 starter motor brush assembly

- 1 Plastic cap
- 2 Star clip
- 3 Commutator end plate screw
- 4 Commutator end plate
- 5 Brush box
- 6 Yoke
- 7 Pole securing screw
- 8 Solenoid connector link
- 9 Pole shoe
- 10 Field coils

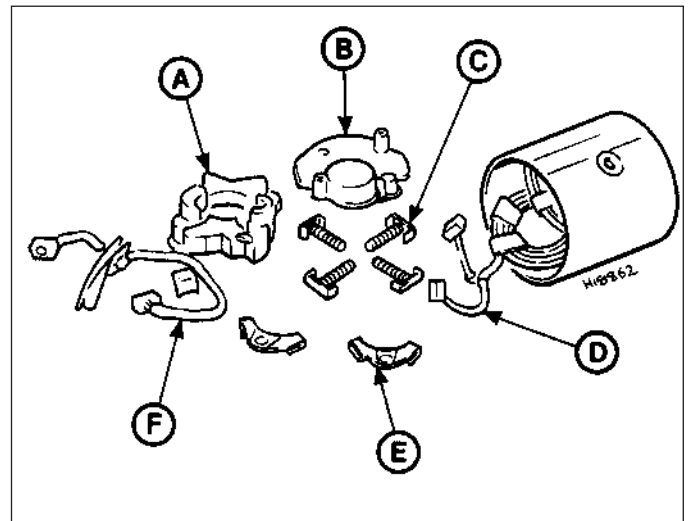

10.38 Lucas M79 starter motor brush plate components

- A Brush plate
- B Brush plate insulator
- C Brush holders and springs
- D Brushes
- E Insulators
- F Brush link

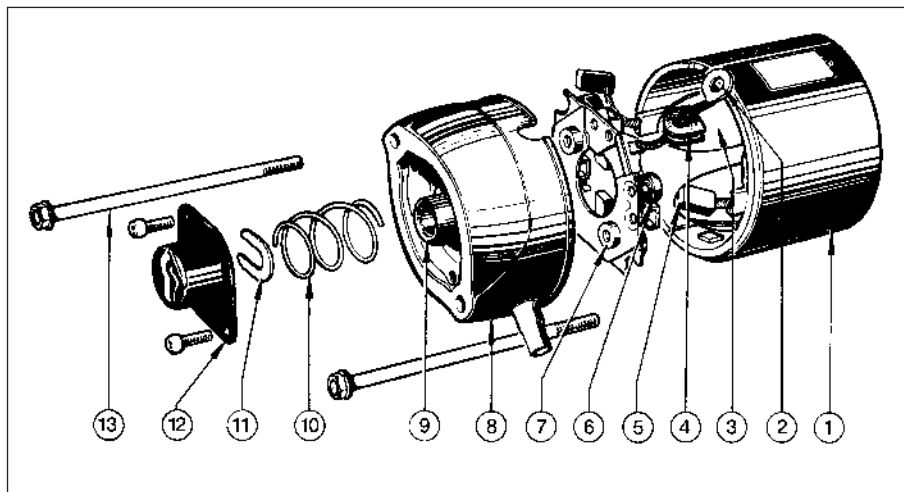

10.47 Nippondenso starter motor brush assembly

- | | |
|----------------------------|---|
| 1 Yoke | 8 Commutator end housing |
| 2 Solenoid connecting link | 9 Bush |
| 3 Pole shoe | 10 Spring |
| 4 Rubber grommet | 11 C-clip |
| 5 Brush | 12 Commutator end housing cap |
| 6 Brush spring | 13 Commutator end housing securing bolt |
| 7 Brush plate | |

41 Locate the brush box over the commutator, position the brushes, then fit the nylon cover over the brushes. Route the brush wiring into the locating channel, then secure the brushes in the channels with the locking clips and springs.

42 Refit the commutator end housing, locating the rubber block in the cut-out in the housing, then secure with the two screws.

43 Refit the spacers and C-clip to the end of the armature shaft, then fit the commutator end housing cap and secure with the two screws.

44 Reconnect the wiring to the solenoid terminal and fit the washer and securing nut.

Nippondenso type

45 With the starter motor removed from the vehicle and cleaned, grip the unit in a vice fitted with soft jaw protectors.

46 Unscrew the retaining nut and washer and disconnect the wiring from the terminal on the solenoid.

47 Remove the two screws securing the commutator end housing cap and remove the cap (see illustration).

48 Remove the C-clip from the groove in the armature shaft, and remove the spring.

49 Unscrew the two bolts and washers, and withdraw the commutator end housing.

50 Withdraw the two field brushes from the brush plate, then remove the brush plate.

51 If the brushes have worn to less than the specified minimum, renew them as a set. To renew the brushes, cut the leads at their midpoint and make a good soldered joint when connecting the new brushes.

52 The commutator face should be clean and free from burnt spots. Where necessary burnish with fine glass paper (not emery) and wipe with a fuel-moistened cloth.

53 Position the brush plate over the end of the armature, aligning the cut-outs in the brush plate with the loops in the field windings. The brush plate will be positively located when the commutator end housing bolts are fitted.

54 Fit the brushes to their locations in the brush plate, and retain with the springs.

55 Fit the commutator end housing and secure with the two bolts and washers.

56 Fit the spring and the C-clip to the end of the armature shaft, then smear the end of the shaft with a little lithium-based grease, and refit the commutator end housing cap, securing with the two screws.

57 Reconnect the wiring to the solenoid terminal and fit the washer and retaining nut.

11 Spark plugs and HT leads - removal, inspection and refitting

Note: The correct functioning of the spark plugs is vital for the correct running and efficiency of the engine. It is essential that the plugs fitted are appropriate for the engine, and the suitable type is specified at the beginning of this Chapter. If this type is used and the engine is in good condition, the spark plugs should not need attention between scheduled replacement intervals. Spark plug cleaning is rarely necessary and should not be attempted unless specialised equipment is available as damage can easily be caused to the firing ends.

Removal

1 Where necessary, for improved access remove the air cleaner and/or the inlet hose.

2 If necessary, identify each HT lead for position, so that the leads can be refitted to their

correct cylinders, then disconnect the leads from the plugs by pulling on the connectors, not the leads. Note that the position of No 1 cylinder HT lead in the distributor cap is marked with either a pip, or a number "1".

3 On 2.0 litre DOHC carburettor models, the location of the spark plugs and the close proximity of the carburettor makes spark plug access difficult, particularly when removing the plugs from cylinders 2 and 3. It is suggested that a 3/8 inch ratchet drive spark plug socket with rubber insert and long extension bar is used, possibly in conjunction with a universal joint adapter. It is also advisable to disconnect No 3 cylinder HT lead from the distributor first, to allow some slack for disconnection at the spark plug.

4 Clean the area around each spark plug using a small brush, then using a plug spanner (preferably with a rubber insert), unscrew and remove the plugs. Cover the spark plug holes with a clean rag to prevent the ingress of any foreign matter.

Inspection

5 The condition of the spark plugs will tell much about the overall condition of the engine.

6 If the insulator nose of the spark plug is clean and white, with no deposits, this is indicative of a weak air/fuel mixture, or too hot a plug. (A hot plug transfers heat away from the electrode slowly - a cold plug transfers it away quickly).

7 If the tip and insulator nose is covered with hard black-looking deposits, then this is indicative that the mixture is too rich. Should the plug be black and oily, then it is likely that the engine is fairly worn, as well as the mixture being too rich.

8 If the insulator nose is covered with light tan to greyish brown deposits, then the mixture is correct and it is likely that the engine is in good condition.

9 The spark plug gap is of considerable importance, as, if it is too large or too small, the size of the spark and its efficiency will be seriously impaired. The spark plug gap should be set to the figure given in the Specifications at the beginning of this Chapter. To set it, measure the gap with a feeler blade, and then bend open, or close the *outer* plug electrode until the correct gap is achieved (see illustrations). The centre electrode should never be bent as this may crack the insulation and cause plug failure, if nothing worse.



11.9a Measuring a spark plug gap using a feeler blade



11.9b Measuring a spark plug gap using a wire gauge



11.9c Adjusting a spark plug gap using a special tool

10 The distributor cap (except on 1.6 and 1.8 litre CVH (R6A type) engines) and the HT leads should be cleaned and checked at the specified intervals. To test the HT leads, remove them together with the distributor cap, then connect an ohmmeter to the end of each lead and its appropriate terminal within the cap in turn (see illustration). If the resistance of any lead is greater than the maximum given in the Specifications, check that the lead connection in the cap is good before renewing the lead.

Refitting

11 Before fitting the spark plugs, check that the threaded connector sleeves are tight and that the plug exterior surfaces are clean. As the plugs incorporate taper seats also make sure that the threads and seats are clean.

12 On DOHC models before refitting the

spark plugs, coat their threads with suitable antiseize compound, taking care not to contaminate the electrodes.

13 Screw in the spark plugs by hand, then tighten them to the specified torque. *Do not exceed the torque figure.*

14 Push the HT leads firmly onto the spark plugs, and where applicable refit the air cleaner and/or inlet hose.

12 Coil - testing, removal and refitting



Testing

All models except 1.6 and 1.8 litre CVH (R6A type)

1 The coil is located on the left-hand side of the engine compartment and is retained by a metal strap (see illustration). It is of high output type and the HT tower should be kept clean at all times to prevent possible arcing. Bosch and Femsco coils are fitted with protective plastic covers and Polmot coils are fitted with an internal fusible link.

2 To ensure that the correct HT polarity at the spark plugs, the LT coil leads must always be connected correctly. The black lead must always be connected to the terminal marked + 115, and the green lead to the terminal marked /1. Incorrect connections can cause poor starting, misfiring, and short spark plug life.

3 To test the coil first disconnect the LT and HT leads. Connect an ohmmeter between



12.1 Ignition coil - CVH model. Plastic cover arrowed

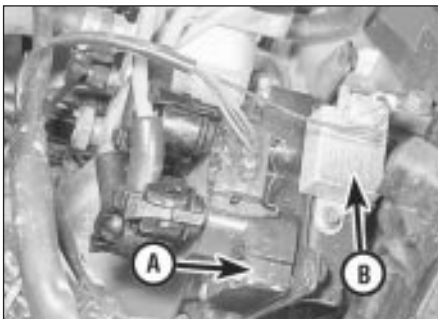

12.4 Ignition coil (A) and suppressor (B) viewed from under vehicle (shroud removed)



12.7 Disconnecting the HT lead from the coil

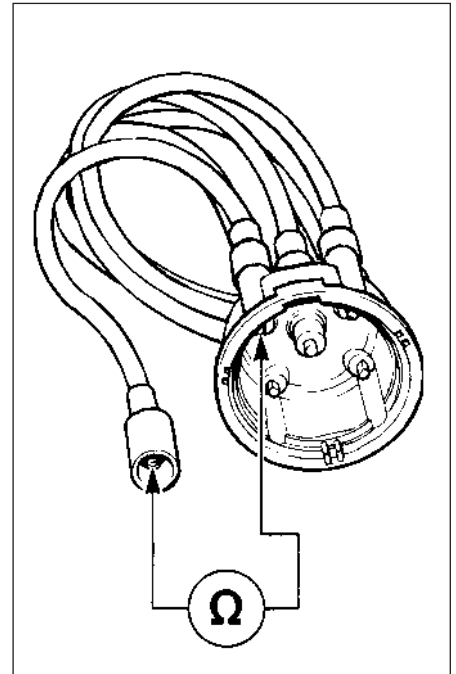

11.10 Method of testing an HT lead with an ohmmeter

both LT terminals and check that the primary winding resistance is as given in the Specifications. Connect the ohmmeter between the HT terminal and either LT terminal and check that the secondary winding resistance is as given in the Specifications. If either winding resistance is not as specified, the coil should be renewed. Reconnect the LT and HT leads on completion.

1.6 and 1.8 litre (R6A type) CVH models

4 The coil fitted to these models is located towards the front right-hand side of the cylinder block (see illustration).

5 Testing of the coil should be entrusted to a Ford dealer or a suitable specialist.

Removal

All models except 1.6 and 1.8 litre CVH (R6A type)

6 Disconnect the battery negative lead, 7 Disconnect the LT and HT leads from the coil (see illustration).

8 Remove the securing screw(s) and detach the coil and strap assembly from the body panel. Note that on models with the ESC system, the coil strap is secured by the top ESC module securing screw. On certain models with the ESC II or EEC IV systems, an "octane adjustment" service lead may be connected to one of the coil securing screws. On 2.0 litre DOHC fuel-injected models, the coil/ignition module heat shield must be removed for access to the coil securing bolts. The heat shield is secured by two screws. Note that on certain models, an earthing lead



12.8a Ignition coil viewed with heat shield removed

and/or a suppressor may be secured by one of the coil securing bolts (see illustrations).

1.6 and 1.8 litre (R6A type) CVH models

- 9 Disconnect the battery negative lead.
- 10 Remove the two securing screws, and withdraw the plastic ignition module shroud.
- 11 Disconnect the ignition coil wiring plug and, where fitted, the suppressor wiring plug, pulling on the plugs, not on the wiring (see illustrations).
- 12 Release the securing lugs, and disconnect the HT leads from the coil, noting their locations to aid refitting.
- 13 Remove the four Torx screws, and withdraw the coil from the cylinder block.

Refitting

- 14 Refitting is a reversal of removal, but ensure that all leads are securely connected.



13.2 Unclipping the distributor screening can - Motorcraft distributor



13.3 HT lead holder on camshaft cover



12.8b Suppressor secured by one of the coil securing bolts

13 Distributor cap and rotor arm (OHC models) - removal and refitting

SOHC models

- 1 Disconnect the battery negative lead.
- 2 Where applicable, unclip the screening can from the top of the distributor and disconnect the earth strap (see illustration).
- 3 If necessary, identify each HT lead for position, so that the leads can be refitted to their correct cylinders, then disconnect the leads from the spark plugs by pulling on the connectors, not the leads. Similarly, disconnect the HT lead from the coil. Where applicable, slide the HT lead holder from the clip on the camshaft cover (see illustration).

Lucas distributors

- 4 Remove the two securing screws and lift off the distributor cap.
- 5 The rotor arm is a push-fit on the end of the distributor shaft.
- 6 Refitting is a reversal of removal, noting that the rotor arm can only be fitted in one position. Ensure that the HT leads are correctly connected.

Bosch distributors

- 7 Prise away the spring clips with a screwdriver and lift off the distributor cap (see illustration). On fuel injection models, disconnect the crankcase ventilation hose from the air inlet hose, then disconnect the air inlet hose from the inlet manifold and the airflow meter for improved access.



13.7 Securing distributor cap with spring clip - Bosch distributor

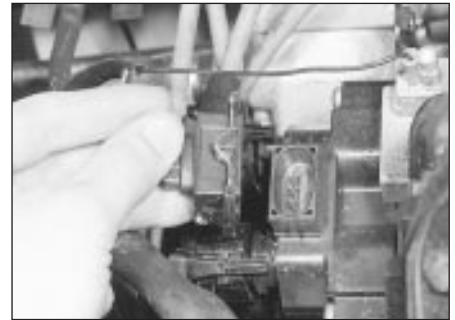

12.11a Disconnecting the coil wiring plug . . .



12.11b . . . and the suppressor wiring plug

- 8 Refitting is a reversal of removal, noting that the rotor arm can only be fitted in one position. Ensure that the HT leads are correctly connected, and on fuel injection models ensure that the air inlet hose clips are correctly aligned (refer to illustration, Section 15, Chapter 4, Part B).

Motorcraft distributors

- 9 For improved access, disconnect the crankcase ventilation hose from the air inlet hose, then disconnect the air inlet hose from the inlet manifold and the airflow meter for improved access.
- 10 Remove the two securing screws and lift off the distributor cap (see illustration).
- 11 Remove the two securing screws and withdraw the rotor arm (disc) (see illustration). Note that on some vehicles, the rotor arm tip may be coated with silicone grease to assist radio interference suppression. Do not attempt to clean the grease off if it is present. If radio interference



13.10 Removing a distributor cap securing screw - Motorcraft distributor



13.11 Removing a rotor arm (disc) securing screw - Motorcraft distributor



13.14a Unclipping the lower section . . .



13.14b . . . and the upper section of the distributor shield

problems are experienced, consult a Ford dealer or an in-car entertainment specialist.

12 Proceed as described in paragraph 6, but additionally ensure that the air inlet hose clips are correctly aligned (refer to illustration, Section 15, Chapter 4, Part B).

DOHC models

13 Disconnect the battery negative lead.

14 Unclip the lower section of the distributor shield from the upper section, then unscrew the two securing nuts, and withdraw the upper section of the shield from the studs on the upper timing chain cover (see illustrations).

15 If necessary, identify each HT lead for position, so that the leads can be refitted to their correct cylinders, then disconnect the leads from the spark plugs by pulling on the

connectors, not the leads. Similarly, disconnect the HT lead from the coil, and release it from the clip on the timing chain cover.

16 Using a suitable Torx key or socket, unscrew the two distributor cap securing screws, then lift off the cap.

17 The rotor arm is a push-fit on the end of the rotor shaft (see illustration).

18 If desired, the rotor housing can be pulled from the timing chain cover.

19 Refitting is a reversal of removal, ensuring that the rotor arm is pushed fully home on the rotor shaft. Make sure that the HT leads are fitted to their correct cylinders. Note that the rotor arm will only fit in one position.

4 If necessary, identify each HT lead for position, so that the leads can be refitted to their correct cylinders, then disconnect the leads from the spark plugs by pulling on the connectors, not the leads. Unclip the HT lead holders from their studs on the camshaft cover (see illustration).

5 Depress the two securing screws and turn them anti-clockwise through 90°, then lift off the distributor cap.

6 Disconnect the HT lead from the coil by pulling on the connector not the lead, and remove the distributor cap.

7 Refitting is a reversal of removal, but ensure that the HT leads are fitted to their correct cylinders.

14 Distributor components (CVH models) - removal and refitting



1 The distributor fitted to the CVH engine is unlike any conventional distributor, in that it has no main body and no adjustments are possible. The distributor is used purely to distribute HT voltage to the spark plugs. To remove the distributor components, proceed as follows.

2 Disconnect the battery negative lead.

Distributor cap

3 Pull the two halves of the distributor cap shroud apart and remove the shroud. Disconnect the earth strap from the tag on the timing cover (see illustration).

Rotor arm and housing

8 With the distributor cap removed as described previously, compress the two lugs on the rotor shaft and withdraw the rotor arm (see illustration).

9 The rotor housing can now be removed by pulling it from the timing cover (see illustration).

10 Refitting is a reversal of removal, but note that the rotor arm can only be fitted in one position.

Rotor shaft

11 The rotor shaft is retained by the camshaft sprocket bolt.

12 To remove and refit the rotor shaft, first remove the timing cover and the camshaft



13.17 Removing the distributor cap and rotor arm



14.3 Distributor cap shroud earth strap connection

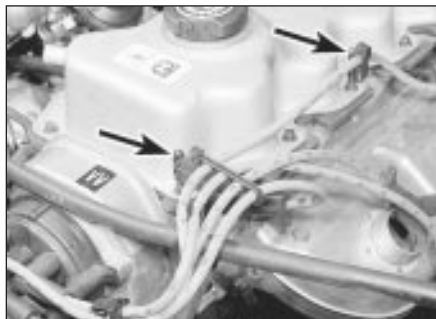

14.4 HT lead holders (arrowed) on camshaft cover



14.8 Removing the rotor arm

sprocket bolt. Note that there is no need to remove the timing belt or the sprockets.

15 Distributor (OHC models) - removal and refitting



Note: During production the engine ignition timing is accurately set using a microwave process, and sealant is applied to the distributor clamp bolt. Removal of the distributor should be avoided except where excessive bearing wear has occurred due to high mileage or during major engine overhaul. A timing light will be required to check the ignition timing after refitting the distributor.

All models except early "Economy"

Removal

- 1 Disconnect the battery negative lead.
- 2 If necessary, identify each HT lead for position, so that the leads can be refitted to their correct cylinders, then disconnect the leads from the spark plugs by pulling on the connectors, not the leads.
- 3 Where applicable, unclip the screening can from the top of the distributor and disconnect the earth strap. On fuel injection models, disconnect the crankcase ventilation hose from the air inlet hose, then disconnect the air inlet hose from the inlet manifold and the airflow meter for improved access.



15.6 Disconnecting vacuum pipe from vacuum advance unit - Bosch distributor



14.9 Removing the rotor housing

- 4 Prise away the spring clips with a screwdriver, or remove the two securing screws, as applicable, and lift off the distributor cap.
- 5 Disconnect the HT lead from the coil by pulling on the connector, not the lead, then slide the HT lead holder from the clip on the camshaft cover, and withdraw the distributor cap.
- 6 Where applicable, disconnect the vacuum pipe from the vacuum advance unit on the side of the distributor (see illustration).
- 7 Using a suitable socket or spanner on the crankshaft pulley bolt, turn the crankshaft to bring No 1 cylinder to the firing point. If the distributor cap is secured by clips, make sure that the clips stay clear of the distributor

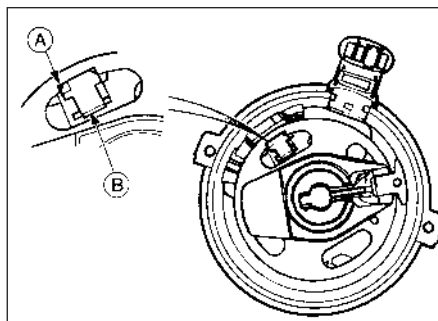

15.7a Lucas distributor showing trigger vane position No 1 cylinder at firing point

A Trigger vane cut-out B Sensor



15.7b Rotor arm tip aligned with scribed line on distributor body - Bosch distributor

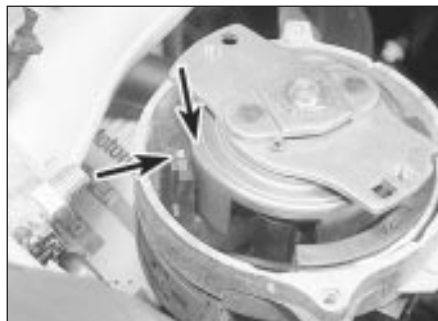

15.7c Trigger vane segment leading edge aligned with sensor rib - Motorcraft distributor

moving parts. No 1 cylinder is at the firing point when:

- a) The relevant timing marks are in alignment.
- b) The tip of the rotor arm is pointing to the position occupied by the No 1 cylinder HT lead terminal in the distributor cap. Note that the position of No 1 HT lead terminal is identified by a pip or a number "1"
- c) On Lucas distributors, the cut-out in the trigger vane is aligned with the sensor (see illustration)
- d) On Bosch distributors, the tip of the rotor arm is aligned with the scribed line on the distributor body (where applicable, remove rotor arm and dust cover, then refit rotor arm to check alignment with scribed line) (see illustration)
- e) On Motorcraft distributors, the tip of the rotor arm is aligned with a notch in the distributor body. Mark the relevant notch (there may be several) for reference when refitting. Also, the leading edge of one of the trigger vane segments is aligned with the rib on the sensor (remove the two securing screws and lift off the rotor arm to view the trigger vane and sensor) (see illustration).

8 Disconnect the distributor wiring plug, where applicable depressing the locking tab(s). Pull on the plug, not the wiring (see illustration).

9 Make alignment marks between the distributor body and the cylinder block.

10 Scrape the sealant from the distributor clamp bolt, then unscrew and remove the bolt and clamp (see illustration).

11 Withdraw the distributor from the cylinder block. As the distributor is removed, the rotor arm will turn clockwise due to the skew gear drive. Note the new position of the rotor arm relative to the distributor body, if necessary making an alignment mark (some distributors already have an alignment mark).

12 Check the distributor spindle for excessive side-to-side movement. If evident, the distributor must be renewed, as the only spares available are the cap, rotor arm, module (where applicable), and driveshaft O-ring (see illustration).



15.8 Disconnecting distributor wiring plug - Bosch distributor

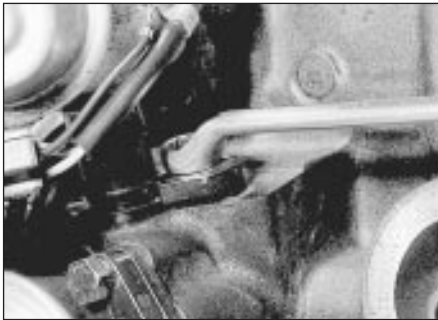

15.10 Unscrewing distributor clamp bolt - Bosch distributor

Refitting

13 Commence refitting by checking that No 1 cylinder is still at the firing point. The relevant timing marks should be aligned. If the engine has been turned whilst the distributor has been removed, check that No 1 cylinder is on its firing stroke by removing the No 1 cylinder spark plug and placing a finger over the plug hole. Turn the crankshaft until compression can be felt, which indicates that No 1 piston is rising on its firing stroke. Continue turning the crankshaft until the relevant timing marks are in alignment.

14 Turn the rotor arm to the position noted in paragraph 11. If a new distributor is being fitted, and no alignment marks are present, transfer the marks from the old distributor to the new distributor.

15 Hold the distributor directly over the aperture in the cylinder block with the previously made marks on the distributor body and cylinder block aligned, then lower the distributor into position. Again, if a new distributor is being fitted, transfer the alignment mark from the old distributor body to the new distributor body. As the skew gear drive meshes, the rotor arm will turn anti-clockwise.

16 With the distributor fitted and the marks on the distributor body and cylinder block aligned, check that the rotor arm is positioned as described in paragraph 7 - if not, withdraw the distributor, re-position the driveshaft and try again.

17 Refit the clamp, then insert and tighten the bolt. Do not fully tighten the bolt at this stage.

18 Refit the distributor wiring plug, and where applicable reconnect the vacuum pipe, and refit the dust cover and/or rotor arm.

19 Refit the distributor cap, and reconnect the HT leads to the spark plugs and coil. Ensure that the leads are refitted to their correct cylinders.

20 Where applicable, refit the screening can to the top of the distributor and reconnect the earth strap. On fuel injection models, reconnect the air inlet hose, ensuring that the clips are correctly aligned (refer to illustration, Section 15, Chapter 4, Part B).



15.12 Removing distributor driveshaft O-ring - Motorcraft distributor

21 Reconnect the battery negative lead.

22 Check and if necessary adjust the ignition timing.

Early "Economy" models

Removal

23 Removal of the distributor fitted to these models is a similar process to that described above.

Refitting

24 Turn the crankshaft to bring No 1 cylinder to the firing point, with the 16° BTDC mark on the crankshaft pulley aligned with the pointer on the crankshaft front oil seal housing, as described above.

25 Fit the new distributor to the engine as described above, then proceed as follows.

26 Cut the original distributor wiring plug from the wiring loom. Make the cut close to the connector.

27 Strip back 10 mm of insulation from each of the wires on the wiring loom, and on the adapter loom supplied with the new distributor.

28 Solder the adapter loom wires to the corresponding identically coloured wires in the main loom.

29 Carefully insulate each individual soldered joint using insulating tape, then apply tape to cover the join between the looms.

30 Fit a new distributor cap (and screening can, where applicable), and connect the HT leads.



16.2a Highlighted timing marks - SOHC engine with cast crankshaft pulley

31 Connect the adapter loom to the distributor.

32 Start the engine, and adjust the ignition timing to the value given in the Specifications at the beginning of this Chapter. Work as described above whilst noting that the vacuum pipe must be left connected.

16 Ignition timing (OHC models) - adjustment



Note: During production the ignition timing is accurately set using a microwave process, and sealant is applied to the distributor clamp bolt. Because the electronic components require no maintenance, checking the ignition timing does not constitute part of the routine maintenance schedule, and the procedure is therefore only necessary after removal and refitting of the distributor. A timing light will be required for this procedure. For details of ignition timing adjustment in order to operate vehicles on unleaded petrol refer to the appropriate Section of this Chapter.

All models except 2.0 litre DOHC

1 Before checking the ignition timing, the following conditions must be met:

- The engine must be at normal operating temperature
- Where applicable, the vacuum pipe to the distributor vacuum unit or electronic module (as applicable) must be disconnected from the vacuum unit or electronic module and plugged
- The idle speed must be below 900 rpm (isolate "idle speed adjustment" wire if necessary)
- Any earthed "octane adjustment" wires must be temporarily isolated

2 Wipe clean the crankshaft pulley timing marks and the pointer on the crankshaft front oil seal housing. Note that two alternative types of pulley may be fitted (see illustration). The desired timing values are given in the Specifications. If necessary, use white paint or chalk to highlight the relevant timing mark(s) (see illustration).

3 Connect a stroboscope timing light to the No 1 cylinder HT lead, following the manufacturer's instructions.

4 With the engine idling at normal operating temperature, point the timing light at the marks on the crankshaft pulley, and check that the appropriate timing mark appears stationary in line with the timing cover pointer. Take care not to get the timing light leads, clothing etc tangled in the cooling fan blades or other moving parts of the engine.

5 If adjustment is necessary, stop the engine, slacken the distributor clamp bolt, and turn the distributor body slightly. Turn the distributor body clockwise to retard the ignition timing (move the timing closer to TDC) and anti-clockwise to advance the timing.

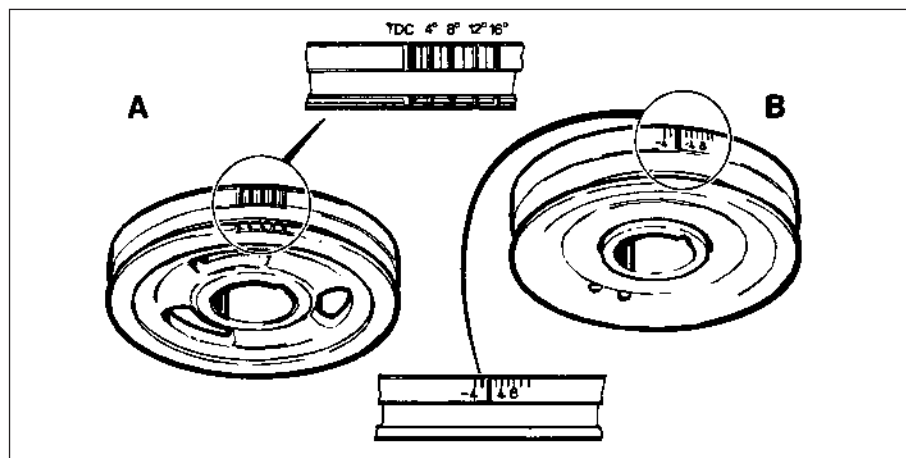

16.2b Crankshaft pulley timing marks - SOHC engine

A Cast pulley

B Pressed steel pulley

Note that the required distributor body movement will be half of the required crankshaft movement (ie an adjustment of 5° in ignition timing will require the distributor body to be turned 2°. Tighten the clamp bolt and re-check the timing.

6 On models with inductive discharge ignition systems, the mechanical and vacuum advance mechanisms can be checked as follows. On all other models, proceed to paragraph 10.

7 With the engine idling, timing light connected, and vacuum pipe disconnected as described in the preceding paragraphs, increase the engine speed to approximately 2000 rpm (if desired, connect a tachometer to the engine in accordance with the manufacturer's instructions). Note the approximate distance which the relevant pulley mark moves out of alignment with the pointer.

8 Reconnect the vacuum pipe to the distributor or electronic module, as applicable, and repeat the procedure given in the previous paragraph, when for the same increase in engine speed, the alignment differential between the pulley mark and pointer should be greater than previously observed.

9 If the pulley mark does not appear to move during the first part of the check, a fault in the distributor mechanical advance mechanism is indicated. No increased movement of the mark during the second part of the check indicates a punctured diaphragm in the distributor vacuum unit, or a leak in the vacuum line.

10 On completion of the adjustments and checks, stop the engine and disconnect the timing light. Where applicable, reconnect the vacuum pipe, if not already done, and reconnect any "octane adjustment" and "idle speed adjustment" wires. Make a final check to ensure that the distributor clamp bolt is tight.

11 Finally, the idle speed and mixture should be checked and adjusted.

2.0 litre DOHC carburettor model

12 The ignition timing is controlled by the ESC II module, and no adjustment is possible.

2.0 litre DOHC fuel injection model

13 The ignition timing is controlled by the EEC IV module, and no adjustment is possible.

17 Ignition timing - adjustment for use with unleaded petrol

Note: Refer to the Specifications Section at the beginning of this Chapter for ignition timing values for use with unleaded petrol.

1 To run an engine on unleaded petrol, certain criteria must be met, and it may be helpful to first describe the various terms used for the different types of petrol:

Normal leaded petrol (4-star, 97 RON): Petrol which has a low amount of lead added during manufacture (0.15 g/litre), in addition to the natural lead found in crude oil.

Unleaded petrol (Premium, 95 RON): Has no lead added during manufacture, but still has the natural lead content of crude oil.

Lead free petrol: Contains no lead. It has no lead added during manufacture, and the natural lead content is refined out. This type of petrol is not currently available for general use in the UK and should not be confused with unleaded petrol.

2 To run an engine continuously on unleaded petrol, suitable hardened valve seat inserts must be fitted to the cylinder head.

3 The OHC engines fitted to the Sierra/P100 range which have suitable valve seat inserts fitted at manufacture can be identified by letters stamped on the cylinder head next to No 4 spark plug as follows:

1.6 litre engines M, MM, N, or NN

1.6 litre engines S or SS

2.0 litre engines L, P, PP, R, or RR

4 All CVH engines have suitable valve seat inserts fitted.

5 Vehicles which have no identification letter stamped on the cylinder head, and are not fitted with suitable valve seat inserts, may still be run on unleaded petrol (although continuous use is not recommended), provided that every fourth tank filling is of normal leaded petrol, ie: three tanks of unleaded petrol followed by one tank of normal leaded petrol.

6 When running an OHC engine on unleaded petrol (Premium, 95 RON), the ignition timing **must** be retarded as described in the following sub-Sections. There is no requirement for ignition timing adjustment when running CVH engines on unleaded petrol.

Inductive discharge ignition system and ESC system

7 On vehicles fitted with an inductive discharge ignition system, or the ESC system, the ignition timing should be retarded as specified.

ESC II and EEC IV systems

8 On vehicles fitted with the ESC II or EEC IV systems, there is a facility for retarding the ignition timing without physically disturbing the distributor.

9 Adjustment is made by earthing one or two wires ("octane adjustment" wires) which terminate in a wiring plug next to the ignition coil. Ideally a service adjustment lead, available from a Ford dealer should be used (**see illustration**). One end of the lead plugs into the "octane adjustment" wiring plug, and the other end should be earthed by fixing to one of the ignition coil securing screws.

10 Cut and insulate the wires in the service lead which are not to be earthed.

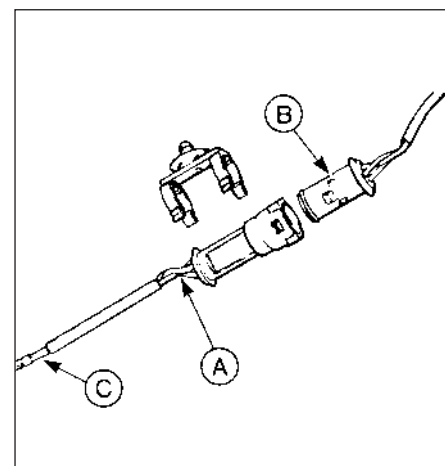

17.9 Service adjustment lead and plug - ESC II and EEC IV systems

A Red, blue and yellow wires

B Plug

C Wire cutting point

System	Degrees of retardation		
	Blue wire	Red wire	Blue and red wires
ESC II (except 1.8 litre models from February 1987)	2	4	6
ESC II (1.8 litre models from February 1987)	4	2	6
EEC IV	4	2	6

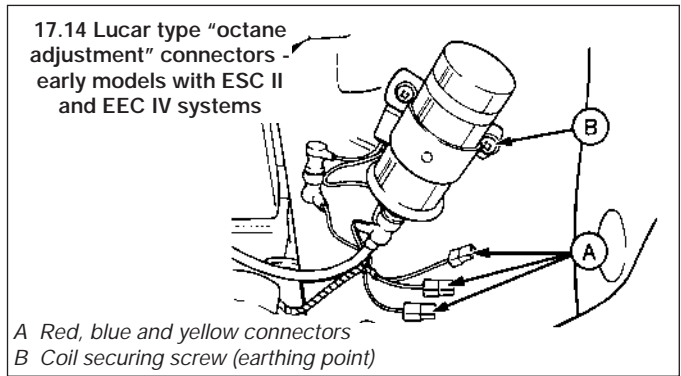

11 The amount of ignition retardation provided by earthing the wire(s) is as shown in the table above.

12 Once the ignition timing has been retarded, the vehicle can be operated on either leaded or unleaded petrol.

13 On 2.0 litre models, if the yellow wire ("idle speed adjustment" wire) in the service lead is earthed, the idle speed will be raised by 75 rpm. If the vehicle already has a single yellow fly lead connected prior to connecting the service lead, ensure that the yellow wire in the service lead is earthed.

14 Note that some early models have coloured "Lucar" connectors fitted in place of the "octane adjustment" wiring plug (see illustration). The principle for ignition timing adjustment on these vehicles is as described previously for vehicles with the "octane adjustment" wiring plug.

15 On completion of ignition timing adjustment, the idle speed and mixture should be checked and adjusted as necessary.

18 Electronic modules - removal and refitting

Note: Refer to Section 1 for precautions to be observed when working with electronic modules.

1 Disconnect the battery negative lead.

All ESC modules except ESC (early "Economy" models)

2 All modules except the ESC Hybrid module are mounted on the left-hand side of the engine compartment (see illustration). The ESC Hybrid module is mounted on the right-hand side of the engine compartment.

3 Disconnect the module wiring plug by pulling on the plug, not the wiring. On ESC II

modules, except those fitted to 1.8 litre models from February 1987, a locking tab at the lower end of the wiring plug must be depressed before unhooking the upper end of the plug from the module. On ESC II modules fitted to 1.8 litre models from February 1987 (see illustration) and ESC Hybrid modules, the wiring plug is secured by a screw which is integral with the plug (see illustrations).

4 Where applicable, disconnect the vacuum pipe from the module (see illustration).

5 Remove the two or three securing screws, as applicable, and withdraw the module from the engine compartment. Note that the top securing screw of the ESC module also secures the ignition coil strap.

6 Refitting is a reversal of removal, but ensure that the underside of the module and the corresponding area of the body panel are clean.

ESC module (early "Economy" models)

7 Remove the module complete with its securing bracket, as described above.

8 Fit the new module, slightly behind the old module position, on the flat vertical surface of the body panel, and secure with the two screws supplied. Note that the module must be mounted against the flat area of the body panel to prevent distortion of the module, and to ensure good heat transfer from the module to the body.

9 Reconnect the module vacuum pipe.

10 Connect the adapter loom supplied with the new module between the module and the old module's wiring plug.

11 Where applicable, refit the coil to its original location.

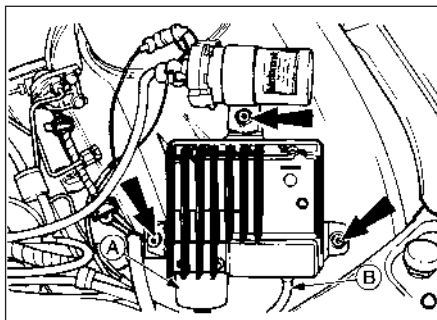

18.2 ESC module securing screws (arrowed)
A Wiring plug B Vacuum pipe

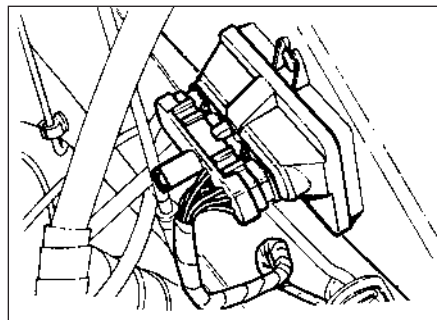

18.3a ESC II module - 1.8 litre models from February 1987



18.3b Disconnecting ESC II module wiring plug



18.3c Disconnecting ESC Hybrid module wiring plug



18.4 Disconnecting ESC II module vacuum pipe

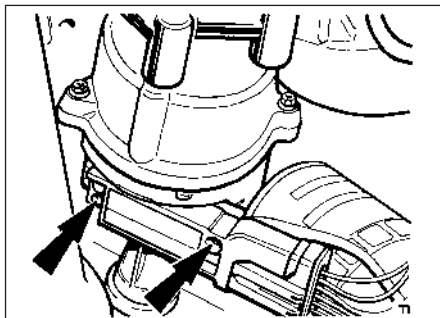

18.14 EEC IV ignition module securing screws (arrowed) - models up to 1987

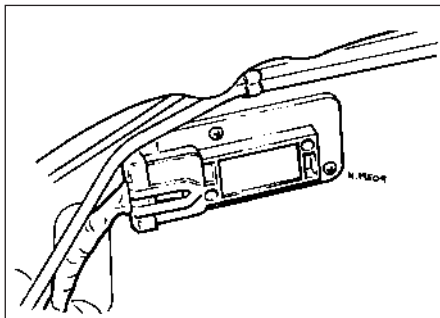

18.16 EEC IV ignition module - models from 1987



18.22 Disconnecting the ignition module wiring plug

EEC IV modules

Ignition module

Models up to 1987

Note: When refitting, the rear face of the module must be coated with heat sink compound. Refer to a Ford dealer for advice if necessary.

12 The module is mounted on the distributor body.

13 Disconnect the distributor wiring plug by depressing the locking tabs. Pull on the plug, not the wiring.

14 Remove the two securing screws from the module, then slide the module downwards and withdraw it (see illustration).

15 Refitting is a reversal of removal, but the rear face of the module must be coated with heat sink compound. Do not force the module into position, as damage to the electrical contacts may result.

Models from 1987

16 The module is mounted on the left-hand side of the engine compartment (see illustration).

17 Disconnect the module wiring plug by depressing the locking tabs. Pull on the plug, not the wiring.

18 Remove the two securing screws and withdraw the module from the engine compartment.

19 Refitting is a reversal of removal, but ensure that the underside of the module and the corresponding area of the body panel are clean.

1.6 and 1.8 litre (R6A type) CVH models

20 The ignition module is located at the front right-hand side of the engine compartment.

21 Disconnect the battery negative lead.

22 Release the securing lug, and pull the wiring plug from the module. Pull on the plug, not on the wiring (see illustration).

23 Remove the two securing screws, and withdraw the module from the body panel.

24 Refitting is a reversal of removal.

2.0 litre DOHC fuel injection models

25 The ignition module is located on the left-hand side of the engine compartment, beneath the coil (see illustration).

26 Disconnect the battery negative lead.

27 Remove the two securing screws, and withdraw the coil/ignition module heat shield.

28 Release the locking lug and disconnect the ignition module wiring plug. Pull on the plug, not on the wiring.

29 Remove the two securing screws, and withdraw the module from the body panel.

30 Refitting is a reversal of removal, ensuring that the underside of the module and the corresponding area of the body panel are clean.

Engine management module

All models except 1.6 and 1.8 litre CVH (R6A type) and 2.0 litre DOHC fuel injection

31 The module is located inside the passenger compartment behind the passenger side facia.

32 Unclip the trim panel from below the glovebox on models up to 1987, or from above the glovebox on models from 1987.

33 Unclip the module retainer and withdraw the module.

34 The wiring plug is secured by a screw which is integral with the plug. Disconnect the wiring plug and remove the module.

35 Refitting is a reversal of removal, noting that the wiring plug will only fit in one position.

1.6 and 1.8 litre (R6A type) CVH models

36 The module is located in the passenger compartment, behind the glovebox.

37 Disconnect the battery negative lead.

38 Open the glovebox, and carefully pull it from its retaining clips.

39 Unclip and withdraw the module from its retaining bracket (see illustration).

40 The wiring plug is secured by a screw which is integral with the plug. Disconnect the wiring plug, and withdraw the module.

41 Refitting is a reversal of removal, noting that the wiring plug will only fit in one position.

2.0 litre DOHC fuel injection models

42 For models up to 1990 refer to the first 5 paragraphs of this sub Section.

43 For models from 1990 refer to the procedure given for 1.6 and 1.8 litre CVH (R6A type) engines.

19 ESC II system components - removal and refitting

Note: Procedures for removal and refitting of the ignition system components and electronic module are given elsewhere in the relevant Sections of this Chapter.

1 Disconnect the battery negative lead.

Engine coolant temperature sensor

All models except 2.0 litre DOHC

2 The sensor is located in the underside of the inlet manifold.



18.25 Ignition module location (arrowed)



18.39 Engine management module withdrawn from its mounting bracket



19.4 Disconnect engine temperature sensor wiring plug - ESC II system



19.11 Removing inlet manifold heater - ESC II system

- 3 Partially drain the cooling system. There is no need to remove the cylinder block drain plug.
 - 4 Disconnect the sensor wiring plug by pulling on the plug, not the wiring (see illustration).
 - 5 Unscrew the sensor from the inlet manifold and remove it.
 - 6 Refitting is a reversal of removal. Fill the cooling system.
- 2.0 litre DOHC models**
- 7 The sensor is located in the side of the inlet manifold. The removal and refitting procedures are as described for the 1.6 and 1.8 litre CVH (R6A type) engines in the relevant Section of this Chapter.

Inlet manifold heater

Note: When refitting the heater, a new gasket and O-ring must be used.

- 8 Do not attempt to remove the heater while it is hot.
- 9 For improved access, remove the air cleaner.
- 10 Disconnect the wiring from the heater.
- 11 Unscrew the three securing bolts and remove the heater. Recover the gasket and O-ring (see illustration).
- 12 Refitting is a reversal of removal, using a new gasket and O-ring, but be careful to tighten the securing bolts evenly, otherwise the heater may tilt and jam in its recess.

Carburettor stepper motor (2.0 litre models)

Note: Irregular idle is not necessarily caused by a faulty or badly adjusted stepper motor. Good electrical contact between the stepper motor plunger and the adjusting screw (which from the throttle position switch) is essential. Before attempting adjustment or renewal of the motor, try the effect of cleaning the plunger and adjusting screw contact faces with abrasive paper followed by switch cleaning fluid. Switch cleaning fluid is available from electronic component shops. Refer to the precautions in Chapter 3 before proceeding.

- 13 Remove the air cleaner.
- 14 Depress the locking tab and disconnect the stepper motor wiring plug. Pull on the plug, not the wiring.
- 15 Remove the four securing screws and withdraw the stepper motor and bracket from the carburettor.
- 16 If desired, the stepper motor can be separated from the bracket by removing the

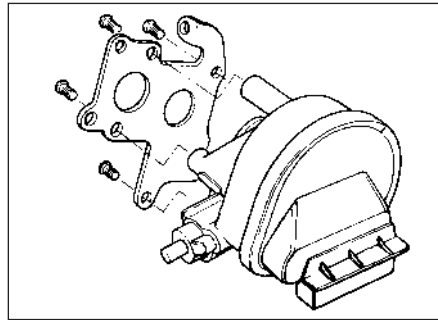

19.16 Carburettor stepper motor adjustment - 2.0 litre models with ESC II system

- four securing screws (see illustration).
- 17 Commence refitting by securing the stepper motor to the bracket, where applicable.
- 18 Refit the stepper motor and bracket to the carburettor and secure with the four screws.
- 19 Reconnect the wiring plug.
- 20 Reconnect the air cleaner vacuum hose to the inlet manifold, and position the air cleaner to one side to allow access to the carburettor and stepper motor.
- 21 Reconnect the battery negative lead.
- 22 Connect a tachometer to the engine in accordance with the manufacturer's instructions.
- 23 Start the engine, then check and if necessary adjust the idle mixture.
- 24 Ensure that all electrical loads are switched off (headlamps, heater blower etc). If the "idle speed adjustment" wire is earthed, temporarily isolate it. Where applicable, ensure that the automatic transmission gear selector lever is in the "N" or "P" position.
- 25 Accelerate the engine to a speed greater than 2500 rpm, allow it to return to idle, then repeat. Insert a feeler blade of 1.0 mm (0.04 in) thickness between the stepper motor plunger and the adjusting screw (see illustration). With the feeler blade in place the engine speed should be 875 ± 25 rpm.
- 26 If adjustment is necessary, remove the tamperproof cap from the adjusting screw locknut. Slacken the locknut, then turn the adjusting screw to achieve the correct engine

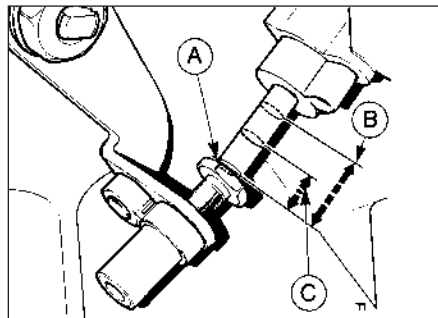

19.30 Carburettor stepper motor plunger positions - 2.0 litre models with ESC II system

- A Vent manifold/start
- B Anti-dieselling
- C Normal idle

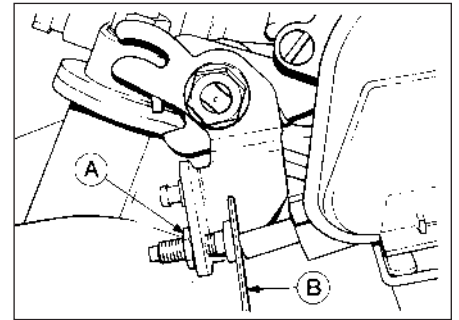

19.25 Carburettor stepper motor adjustment - 2.0 litre models with ESC II system

- A Locknut
- B Feeler blade

- speed and tighten the locknut.
 - 27 Repeat the procedure given in paragraph 24 and check that the engine speed is still correct. Readjust if necessary.
 - 28 Stop the engine, remove the feeler blade, and disconnect the tachometer.
 - 29 Refit the air cleaner, ensuring that the vacuum hose is securely connected. If the "idle speed adjustment" wire was previously earthed, reconnect it.
 - 30 Re-start and then stop the engine, observing the movement of the stepper motor plunger. Immediately after stopping the engine, the plunger should move to the "anti-dieselling" position, and after a few seconds it should extend to the "vent manifold/start" position (see illustration).
 - 31 Re-check and adjust the idle mixture.
 - 32 If necessary, refit the tamperproof caps to the mixture adjustment screw and the stepper motor adjustment screw locknut.
- Crankshaft speed/position sensor (2.0 litre DOHC models)**
- 33 The sensor is located at the right-hand rear of the cylinder block behind the oil filter.
 - 34 Disconnect the battery negative lead.
 - 35 Access is most easily obtained from underneath the vehicle. To improve access, apply the handbrake, then jack up the front of the vehicle and support it securely on axle stands (see "Jacking and Vehicle Support").
 - 36 Disconnect the wiring plug from the sensor.
 - 37 Remove the securing screw, and withdraw the sensor from its location in the cylinder block (see illustration).



19.37 Removing the crankshaft speed/position sensor (engine removed)

- 38 Before refitting the sensor, examine the O-ring, and renew it if damaged or worn.
 39 Refitting is a reversal of removal, noting the torque setting for the sensor screw.

20 ESC Hybrid system components - removal and refitting



Note: Procedures for removal and refitting of the ignition system components and electronic module are given elsewhere in the relevant Sections of this Chapter.

- 1 Disconnect the battery negative lead.

Crankshaft speed/position sensor

- 2 The sensor is mounted in a bracket on the timing cover.
 3 Disconnect the sensor wiring plug by pulling on the plug, not the wiring (see illustration).
 4 Slacken the sensor clamping screw and slide the sensor from its bracket.
 5 Refitting is a reversal of removal, but the clearance between the sensor and the toothed wheel on the crankshaft must be set at 1.0 mm (0.04 in). This can be achieved by inserting a suitable length of wire or rod with a diameter of 1.0 mm (0.04 in) between the sensor and the toothed wheel (see illustration). Do not overtighten the clamping screw, as damage to the sensor may result.



20.3 Disconnecting crankshaft speed/position sensor wiring plug - ESC Hybrid system

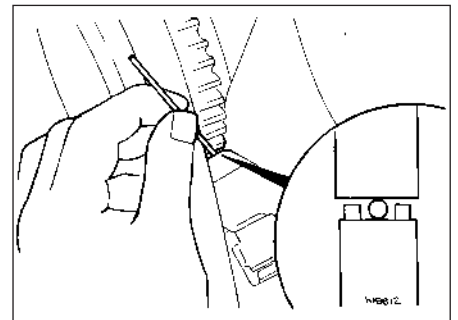

20.5 Setting the gap between the crankshaft speed/position sensor and the crankshaft toothed wheel - ESC Hybrid system

Engine coolant temperature sensor

- 6 The sensor is located in the side of the inlet manifold (see illustration).
 7 Partially drain the cooling system.
 8 Disconnect the sensor wiring plug by pulling on the plug, not the wiring.
 9 Unscrew the sensor from the inlet manifold and remove it.
 10 Refitting is a reversal of removal. Fill the cooling system.

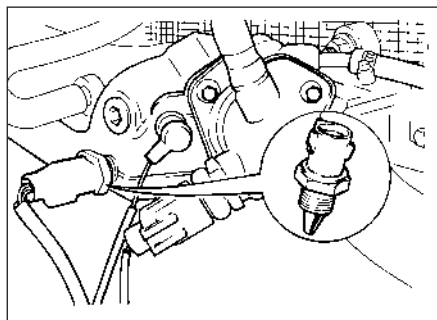

20.6 Engine coolant temperature sensor location - ESC Hybrid system



20.13 Disconnecting air charge temperature sensor wiring plug - ESC Hybrid system

Air charge temperature sensor

- 11 The sensor is located in the base of the air cleaner.
 12 Remove the air cleaner.
 13 Disconnect the sensor wiring plug by pulling on the plug, not the wiring (see illustration).

- 14 Unscrew the sensor from the air cleaner using a suitable spanner.
 15 Refitting is a reversal of removal. Refit the air cleaner. Ensure that the vacuum hose is securely connected.

Electric choke heater

- 16 The electric choke heater is an integral part of the automatic choke housing on the carburettor. Removal and refitting of the choke housing is covered in Chapter 4.
 17 The operation of the electric choke heater relay can be checked by starting the engine from cold, and placing a finger on the relay (see illustration). It should be possible to feel the relay switching on and off. If this is not the case, renew the relay.

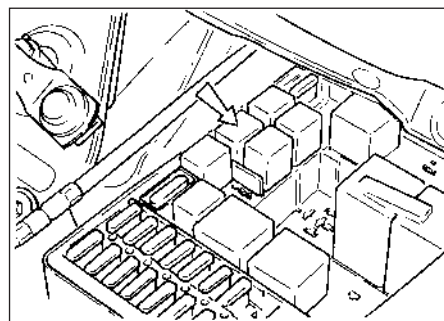

20.17 Electric choke heater relay location (arrowed) in main fusebox - ESC Hybrid system

Throttle damper control solenoid

- 18 The solenoid is on the right-hand side of the engine compartment (see illustration).



20.18 Throttle damper control solenoid - ESC Hybrid system

- 19 Disconnect the solenoid wiring plug by pulling on the plug, not the wiring.
 20 Disconnect the two vacuum pipes from the solenoid, noting their locations for use when refitting.
 21 Remove the securing screw and withdraw the solenoid from the body panel.
 22 Refitting is a reversal of removal, but note that the locating lug on the solenoid bracket should engage with the body panel, and make sure that the vacuum pipes are correctly connected.

Throttle damper

- 23 Remove the air cleaner.
 24 Disconnect the vacuum pipe from the throttle damper.

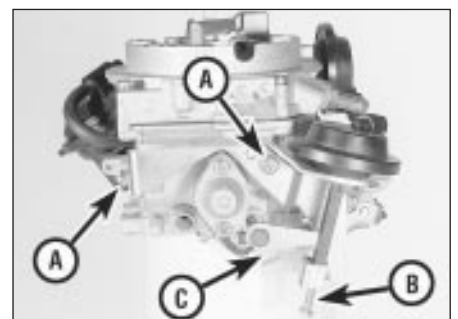

20.25 Throttle damper assembly - ESC Hybrid system

- A Securing screws C Throttle lever
 B Adjusting screw

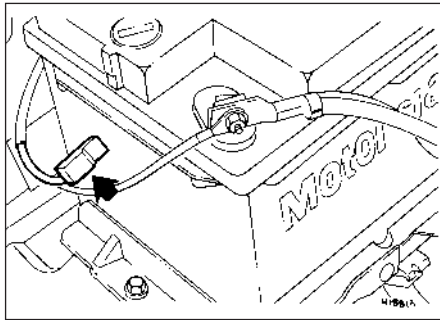

20.32 Service adjustment lead location (arrowed) - ESC Hybrid system

25 Remove the two securing screws and detach the throttle damper and bracket assembly from the carburettor (see illustration).

26 Commence refitting by securing the throttle damper and bracket assembly to the carburettor with the two screws. Ensure that the throttle lever is correctly positioned in the slot in the throttle damper actuating arm.

27 Reconnect the vacuum pipe to the throttle damper.

28 Reconnect the air cleaner vacuum hose to the inlet manifold, and reconnect the air change temperature sensor wiring plug, then place the air cleaner to one side to allow access to the throttle damper.

29 Reconnect the battery negative lead.

30 Connect a tachometer to the engine in accordance with the manufacturer's instructions.

31 Start the engine, then check and if necessary adjust the idle speed and mixture.

32 Earth the "service adjustment" lead, located in the battery negative wiring loom (see illustration), for a minimum of 10 seconds. The throttle damper actuating arm should move to the fully retracted position, raising the engine speed.

33 The engine speed should stabilise at 1700 ± 100 rpm. If adjustment is necessary, turn the adjusting screw on the end of the throttle damper actuating arm to give the correct speed. Turn the screw clockwise to increase the engine speed, or anti-clockwise to reduce the engine speed.



21.9 Crankshaft speed/position sensor (arrowed) viewed from front of engine with shroud removed

34 On completion of adjustment, stop the engine and disconnect the tachometer.

35 Where necessary, ensure that any tamperproof seals are refitted, then refit the air cleaner, ensuring that the vacuum hose is securely connected. Isolate the "service adjustment" lead.

36 Start the engine and check that normal idle speed is resumed, then stop the engine.

21 EEC IV system components - removal and refitting

Note: Procedures for removal and refitting of the ignition system components and electronic module are given elsewhere in the relevant Sections of this Chapter.

Engine coolant temperature sensor

2.0 litre SOHC fuel injection models

1 For details of engine coolant temperature sensor removal and refitting, refer to the Section appertaining to the ESC II system.

1.6 and 1.8 litre (R6A type) CVH models

2 The sensor is located in the side of the inlet manifold.

3 Disconnect the battery negative lead.

4 Partially drain the cooling system.

5 Disconnect the sensor wiring plug by pulling on the plug, not the wiring (see illustration).

6 Unscrew the sensor from the inlet manifold and remove it.

7 Refitting is a reversal of removal. Refill the cooling system.

2.0 litre DOHC fuel injection models

8 The sensor is located in the side of the inlet manifold, behind the throttle body. The removal and refitting procedure is as described for the 1.6 and 1.8 litre (R6A type) CVH models above.

Crankshaft speed/position sensor

1.6 and 1.8 litre (R6A type) CVH models

1.6 litre

9 The sensor is located at the left-hand rear of the cylinder block, above the starter motor (see illustration).



21.17 Air charge temperature sensor location on 1.6 litre engines (arrowed)



21.5 Disconnecting the engine coolant temperature sensor wiring plug

10 Disconnect the battery negative lead.

11 Remove the securing screw, and withdraw the sensor shroud.

12 Disconnect the sensor wiring plug.

13 Remove the Torx securing screw, and withdraw the sensor.

14 Refitting is a reversal of removal.

1.8 litre

15 Proceed as described for the ESC Hybrid module. If a new sensor (not the original unit) is being fitted, position it in the mounting bracket so that it is in actual contact with one of the teeth of the toothed wheel on the crankshaft. Hold the sensor in this position, and tighten the clamping screw. New sensors have projections on their base, which will wear away when the engine is cranking, and automatically set the specified clearance.

2.0 litre DOHC fuel injection models

16 This procedure is as described for the 2.0 litre DOHC carburettor models (ESC II module).

Air charge temperature sensor

1.6 and 1.8 litre (R6A type) CVH models

17 The sensor is located in the side of the CFI unit on 1.6 litre engines (see illustration), and on the inlet manifold on 1.8 litre engines.

18 Disconnect the battery negative lead.

19 Disconnect the sensor wiring plug by pulling on the plug, not the wiring.

20 Unscrew the sensor from its location, and remove it.

21 Refitting is a reversal of removal, but coat the threads of the sensor with suitable sealant before fitting.

2.0 litre DOHC fuel injection models

22 The sensor is located in the upper section of the inlet manifold.

23 Disconnect the battery negative lead.

24 Disconnect the sensor wiring plug by pulling on the plug, not the wiring (see illustration).

25 Unscrew the sensor from the inlet manifold, and remove it.

26 Refitting is a reversal of removal, noting the torque setting for the sensor.



21.24 Disconnecting the air charge temperature sensor wiring plug

Vehicle speed sensor

1.6 and 1.8 litre CVH (R6A type) and 2.0 litre DOHC fuel injection models

27 The sensor is located in the left-hand side of the gearbox/transmission.

28 Disconnect the battery negative lead.

29 Jack up the vehicle and support it securely on axle stands (see "Jacking and Vehicle Support").

30 Detach the sensor wiring connector from its bracket, and separate the two halves of the connector.

31 Unscrew the securing bolt, and withdraw the wiring connector bracket, noting its orientation.

32 Withdraw the sensor from the gearbox/transmission casing (see illustration).

33 Before refitting the sensor, examine the O-ring, and renew if damaged or worn.

34 Refitting is a reversal of removal, ensuring that the wiring connector bracket is correctly located.

Manifold absolute pressure (MAP) sensor

1.6 and 1.8 litre CVH (R6A type) and 2.0 litre DOHC fuel injection models

35 The sensor is located at the rear right-hand side of the engine compartment (see illustration).

36 Disconnect the battery negative lead.

37 Remove the two screws securing the sensor to the body panel, and carefully withdraw the sensor, taking care not to strain



21.42 Disconnecting the fuel temperature sensor wiring plug



21.32 Withdrawing the vehicle speed sensor from the gearbox casing

the wiring.

38 Disconnect the wiring plug from the sensor, pulling on the plug, not the wiring, then disconnect the vacuum hose and remove the sensor.

39 Refitting is a reversal of removal.

Fuel temperature sensor - removal and refitting

2.0 litre DOHC fuel injection models

40 The sensor is located in the top of the fuel rail.

41 Disconnect the battery negative lead, and to improve access, disconnect the wiring plug from the air charge temperature sensor (in the inlet manifold). Disconnect the sensor wiring plug by pulling on the plug, not the wiring.

42 Disconnect the fuel temperature sensor wiring plug, again pulling on the plug (see illustration).

43 Unscrew the sensor from the fuel rail, and remove it.

44 Refitting is a reversal of removal, noting the torque setting for the sensor.

22 Spark control system components (carburettor models) - removal and refitting



Spark delay and sustain valves

1 Disconnect the vacuum pipes at the valve and withdraw the valve.

2 When refitting a spark delay valve, the valve must be positioned with the black end (marked "CARB") towards the carburettor and the coloured end (marked "DIST") towards the distributor or electronic module (as applicable).

3 When refitting a spark sustain valve, the valve must be positioned with the end marked "VAC" towards the carburettor and the side marked "DIST" towards the distributor or electronic module (as applicable).



21.35 Manifold absolute pressure (MAP) sensor location

Ported vacuum switch

4 Where fitted, the switch(es) may be located in the inlet manifold and/or in an adapter fitted in one of the coolant hoses.

5 To remove a switch, partially drain the cooling system. Note that there is no need to remove the cylinder block drain plug.

6 Mark the vacuum pipes for location so that they can be refitted in their correct positions, then disconnect the pipes from the switch.

7 Unscrew the valve from its location.

8 Refitting is a reversal of removal, ensuring that the vacuum pipes are correctly connected. Refill the cooling system.

Fuel trap

9 Disconnect the vacuum pipes at the fuel trap and withdraw the fuel trap.

10 When refitting, the fuel trap must be positioned with the black end (marked "CARB") towards the carburettor, and the white side (marked "DIST") towards the distributor, electronic module, or ported vacuum switch (as applicable) (see illustration).

Spark control system additional components

11 According to model, engine and equipment, additional components such as one-way valves or solenoids may also be fitted as part of the spark control system.

12 The removal and refitting procedures for these components are basically as described previously, and provided that all attachments are marked for position prior to removal, no problems should be encountered.

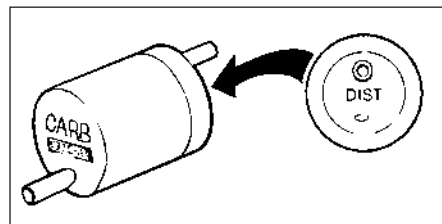

22.10 Fuel trap vacuum connection markings