





Chapter 11

Suspension and steering

Contents

Front anti-roll bar - removal and refitting	7	Rear suspension and final drive unit assembly (Saloon, Hatchback and Estate models) - removal and refitting	10
Front anti-roll bar-to-lower arm compliance bushes - renewal	8	Rear suspension/final drive unit rear mounting (Saloon Hatchback and Estate models) - renewal	16
Front hub carrier - removal and refitting	5	Rear suspension front mounting (Saloon, Hatchback and Estate models) - renewal	15
Front suspension crossmember - removal and refitting	2	Rear suspension leaf spring (P100 models) - removal and refitting	19
Front suspension lower arm - removal, overhaul and refitting	3	Rear suspension leaf spring bush (P100 models) - renewal	21
Front suspension lower arm inner pivot bush - renewal	9	Rear suspension leaf spring shackle (P100 models) - removal and refitting	20
Front suspension strut - removal, overhaul and refitting	4	Rear suspension lower arm (Saloon, Hatchback and Estate models) - removal and refitting	11
Front wheel - alignment checking and adjusting	34	Rear wheel bearings - renewal	14
Front wheel bearings - renewal	6	Steering column adjuster - dismantling and reassembly	25
General information	1	Steering column - removal and refitting	24
Manual steering gear - removal and refitting	27	Steering gear rubber gaiter - renewal	32
Power steering fluid circuit - bleeding	31	Steering intermediate shaft and flexible coupling - removal and refitting	26
Power steering fluid hoses - removal and refitting	30	Steering wheel - centralising	23
Power steering gear - removal and refitting	28	Steering wheel - removal and refitting	22
Power steering pump - removal and refitting	29	Tie-rod end - removal and refitting	33
Rear anti-roll bar (Saloon, Hatchback and Estate models) - removal and refitting	17		
Rear coil spring (Saloon, Hatchback and Estate models) - removal and refitting	13		
Rear shock absorber - removal and refitting	12		
Rear suspension and axle assembly (P100 models) - removal and refitting	18		

Degrees of difficulty

Easy , suitable for novice with little experience 	Fairly easy , suitable for beginner with some experience 	Fairly difficult , suitable for competent DIY mechanic 	Difficult , suitable for experienced DIY mechanic 	Very difficult , suitable for expert DIY or professional 
---	--	--	---	--

Specifications

Front suspension

Type Independent by MacPherson struts with coil springs and integral telescopic shock absorbers. Anti-roll bar fitted to all models

Rear suspension

Type:
 Saloon, Hatchback and Estate models Independent by semi-trailing arms and coil springs with telescopic shock absorbers mounted behind coil springs on Saloon and Hatchback models but concentric with coil springs on Estate models. Self-levelling rear shock absorbers on certain Estate models. Anti-roll bar fitted to certain models
 P100 models Live beam axle with leaf springs and telescopic shock absorbers

Steering

Type Rack-and-pinion steering gear linked to collapsible steering column by flexible coupling and universal joint. Power steering available on certain models

Front wheel alignment*

Production toe-setting:
 Saloon, Hatchback and Estate models 2.0 mm (0.08 in) ± 1.0 mm (0.04 in) toe-in
 P100 models 2.0 mm (0.08 in) ± 2.0 mm (0.08 in) toe-in
 Service tolerance before adjustment is required 0.5 mm (0.02 in) toe-out to 4.5 mm (0.18 in) toe-in

*Toe-setting figures are quoted for vehicle at kerb weight with 3.0 litres (0.66 gallons) of fuel in tank

11•2 Suspension and steering

Wheels

Type	Pressed steel or alloy
Size:	
Saloon, Hatchback and Estate models:	
Steel	13 x 4.50 in, 13 x 5.50 in, or 14 x 5.50 in
Alloy	14 x 5.50 in
P100 models	14 x 5.50 in

Tyre sizes

Note: *Manufacturers often modify tyre sizes and pressure recommendations. The following is intended as a guide only. Refer to your vehicle handbook or a Ford dealer for the latest recommendations*

Saloon and Hatchback models	165 R 13H, 165 R 135, 165 R 13T, 185/70 R 13H, 185/70 R 135, 185/70 R 13T, 195/60 R 14H, 195/60 VR 14 or 195/65 R 14T
Estate models	175 R 13H, 175 R 135, 175 R 13T, 195/70 R 13H, 195/65 R 14T, 195/60 R 14H or 195/60 VR 14 P100 models 185R 14 8PR

Tyre pressures (cold): lbf/in² (bar):

	Front	Rear
All Saloon, Hatchback and Estate models with normal load*	26 (1.8)	26 (1.8)
All Saloon and Hatchback models with full load	29 (2.0)	36 (2.5)
Estate models with full load:		
175 R 13H, 175 R 135, 175 R 13T, 195/70 R 13H and 195/65 R 14T	29 (2.0)	48 (2.8)
195/60 R 14H and 195/60 VR 14	29 (2.0)	36 (2.5)
P100 models with light load	26 (1.8)	36 (2.5)
P100 models with full load	50 (3.5)	65 (4.5)

*Normal load is defined as up to three passengers (or equivalent). For sustained high speeds add 1.5 lbf/in² (0.1 bar) for every 6 mph (10 km/h) over 100 mph (160 km/h)

†A light load is defined as one passenger plus up to 100 kg (220 lb) payload

Torque wrench settings

	Nm	lbf ft
Roadwheel nuts		
Wheelnuts:		
Saloon, Hatchback and Estate models (steel and alloy wheels)	70 to 100	52 to 74
P100 models	85 to 90	63 to 66
Hub nuts:		
Saloon, Hatchback and Estate models	310 to 350	229 to 258
P100 models	390 to 450	288 to 332

Front suspension

Strut upper mounting nut	40 to 52	30 to 38
Hub carrier-to-strut pinch-bolt	77 to 92	57 to 68
Crossmember-to-underbody bolts	70 to 90	52 to 66
Engine mounting-to-crossmember nut:		
Saloon, Hatchback and Estate models	50 to 70	37 to 52
P100 models	41 to 58	30 to 43
Anti-roll bar-to-lower arm nut	70 to 110	52 to 81
Anti-roll bar U-clamp-to-underbody bolts	55 to 70	41 to 52
Lower arm-to-hub carrier balljoint nut	65 to 85	48 to 63
Lower arm inner pivot bolt:		
Stage 1 ("clamping" torque)	45	33
Loosen fully, then Stage 2 ("snug" torque)	15	11
Stage 3	Tighten through a further 90°	

Rear suspension

Saloon, Hatchback and Estate models:		
Lower arm-to-crossmember pivot bolts	80 to 95	59 to 70
Front guide plate-to-underbody bolts	41 to 51	30 to 38
Front guide plate-to-crossmember bolt	100	74
Suspension/final drive unit rear mounting-to-underbody bolts (gold coloured)	60	44
Suspension/final drive unit rear mounting-to-final drive unit rear cover bolts	40 to 50	30 to 37
Anti-roll bar-to-underbody bracket bolts	20 to 25	15 to 18
Hub carrier/brake backplate-to-lower arm bolts*:		
Type X	52 to 64	38 to 47
Type Y	80 to 100	59 to 74
Hub nut	250 to 290	185 to 214

*See Section 15

Torque wrench settings (continued)	Nm	lbf ft
P100 models:		
Shock absorber-to-chassis crossmember bolt	60 to 70	44 to 52
Leaf spring-to-front bracket bolt	157 to 196	116 to 145
Leaf spring-to-spring shackle bolt	157 to 196	116 to 145
Spring shackle-to-underbody bolt	80 to 85	59 to 63
Axle-to-leaf spring U-bolt nuts	39 to 58	29 to 43
Manual steering		
Steering gear-to-crossmember bolts:		
Stage 1 ("clamping" torque)	45	33
Loosen fully, then Stage 2 ("snug" torque)	15	11
Stage 3	Tighten through a further 90°	
Steering column adjuster through-bolt	6 to 8	4 to 6
Tie-rod end locknut	57 to 68	42 to 50
Tie-rod end-to-hub carrier nut*	20 to 32	15 to 24
Tie-rod-to-steering rack balljoint	72 to 88	53 to 65
Steering wheel nut	45 to 55	33 to 41
Intermediate shaft-to-inner column clamp bolt	20 to 25	15 to 18
Flexible coupling-to-steering gear clamp nut	24 to 26	17 to 19
Column mounting pinch-bolt	45 to 55	33 to 41
Pinion retaining nut	70 to 100	52 to 74
Slipper plug†	4 to 5	3 to 4
*Tighten nut to specified torque and then tighten to next available split pin hole		
†Tighten nut to specified torque and then loosen off 60° to 70°		
Power steering (where different to manual steering)		
Tie-rod to steering rack balljoint	70 to 77	52 to 57
Flexible coupling-to-steering gear clamp bolt	16 to 20	12 to 15
Intermediate shaft-to-inner column clamp bolt	16 to 20	12 to 15
Pinion locknut	37 to 47	27 to 35
Slipper plug	3 to 4	2 to 3
Pump rear support bar nut and bolt	41 to 51	30 to 38
Pump mounting bracket-to-engine bolts	52 to 64	38 to 47
Pump pulley bolt	10 to 12	7 to 9
Fluid hose-to-pinion housing bolt	21 to 26	15 to 19
Fluid pressure hose-to-pump union	26 to 31	19 to 23
Fluid return hose-to-pump union	16 to 20	12 to 15

1 General information

The front suspension is of independent MacPherson strut type incorporating coil springs and integral telescopic shock absorbers. The lower end of each strut is attached to a hub carrier, which carries the wheel hub and bearings, and the brake assembly. The lower end of each hub carrier is attached to a suspension lower arm by a sealed balljoint. The inboard ends of the lower arms are attached to the front suspension crossmember and the lower arms thus provide lateral location for the strut assemblies. The upper end of each strut is bolted to a suspension turret on the vehicle body. An anti-roll bar is mounted to the rear of the lower arms, and resists the roll tendency of the front suspension.

On Saloon, Hatchback and Estate models, the rear suspension is also of independent type, incorporating semi-trailing arms, coil springs and telescopic shock absorbers. The semi-trailing arms are attached to the suspension crossmember at their forward ends, and to the hub carriers at the rear. The

coil springs are located between the semi-trailing arms and the vehicle underbody. On Saloon and Hatchback models, the shock absorbers are mounted behind the coil springs, but on Estate models they are concentric with the coil springs. On some Estate models the shock absorbers are of the self-levelling type. The suspension crossmember is attached to the vehicle underbody, and to the final drive unit. Certain models are fitted with an anti-roll bar which is mounted to the rear of the final drive unit, and is attached to the semi-trailing arms by connecting links.

The rear suspension on P100 models consists of a beam axle located and supported by a leaf spring on each side, and utilizing telescopic shock absorbers to control vertical movement. The hub and brake assemblies are attached directly to each side of the axle. The axle is bolted to the leaf springs using U-bolts and counterplates, and the shock absorbers are attached to the counterplates at their lower ends and the vehicle underbody at their upper ends.

The steering gear is of the conventional rack and pinion type located ahead of the front wheels. Movement of the steering wheel

is transmitted to the steering gear by means of a shaft containing a universal joint. The front hub carriers are connected to the steering gear by tie-rods, each having an inner and outer balljoint. Power-assisted steering is available on some models, assistance being provided hydraulically by an engine-driven pump.

2 Front suspension crossmember - removal and refitting



Removal

- 1 Remove the steering gear.
- 2 Support the engine with a jack and interposed block of wood under the sump.
- 3 Unscrew and remove the engine mounting nuts from the top of the mountings in the engine bay (see illustration).
- 4 Raise the engine slightly with the jack, and ensure that it is safely supported, and just clear of the engine mounting rubbers.
- 5 Unscrew and remove the nuts, washers and pivot bolts securing the lower arms to the crossmember, and pull the arms from the crossmember. Note that the pivot bolt heads face to the rear of the vehicle.

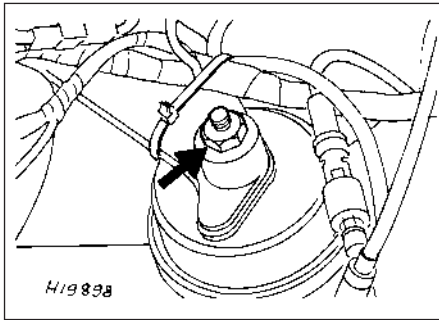

2.3 Engine mounting nut (arrowed)

6 Where applicable, remove the brake pipes from the clips on the crossmember, taking care not to strain them, and detach any cables or electrical leads which may be secured with clips or cable-ties, noting their positions.

7 Support the crossmember with a jack, then unscrew and remove the four mounting bolts (see illustration).

8 Lower the crossmember and withdraw it from under the vehicle.

9 If desired, the engine mountings can now be unbolted from the crossmember.

Refitting

10 Refitting is a reversal of removal, but bear in mind the following points.

11 Do not tighten the lower arm pivot bolts until the weight of the vehicle is resting on its wheels. This is to prevent "wind up" of the rubber bushes which will occur when the vehicle is lowered if the bolts have been tightened with no load on the suspension. The following procedure must be used when tightening the pivot bolts. Tighten the bolt to the specified "clamping" torque, then loosen the bolt fully. Re-tighten to the specified "snug" torque and then further tighten the bolt through the specified angle.

12 Refit any cables or electrical leads in their original positions, where applicable.

13 When lowering the engine onto its mountings, ensure that the locating pegs on the mountings engage with the holes in the mounting brackets.

3 Front suspension lower arm - removal, overhaul and refitting

Note: A balljoint separator tool will be required for this operation.

Removal

1 To improve access, raise the front of the vehicle on ramps. Do not jack the vehicle up at this stage. Apply the handbrake.

2 Unscrew and remove the nut, washer and pivot bolt securing the relevant lower arm to the crossmember (see illustration).

3 Remove the anti-roll bar-to-lower arm securing nut and recover the dished washer and plastic cover (where applicable) (see illustration).

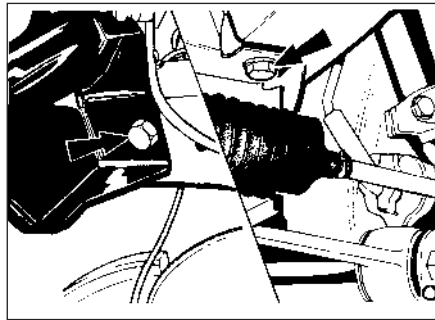

2.7 Front suspension crossmember mounting bolts (arrowed)

4 Ensure that the handbrake is applied, jack up the front of the vehicle and support on axle stands (see "Jacking and Vehicle Support").

5 Remove the split pin and unscrew the castellated nut from the lower arm balljoint. Using a balljoint separator tool, disconnect the lower arm from the hub carrier. The lower arm can now be withdrawn from the vehicle. Recover the remaining dished washer and plastic cover (where applicable) from the end of the anti-roll bar.

Overhaul

6 If the lower arm has been removed due to a worn balljoint, the complete arm must be renewed.

7 The anti-roll bar compliance bushes can be renewed as described in Section 8, but note that the bushes on both sides of the vehicle must be renewed at the same time. The lower arm inner pivot bush can be renewed as described in Section 9.

Refitting

8 To refit the lower arm, proceed as follows.

9 Fit the shallow dished washer (colour coded black or green) and the plastic cover (where applicable) to the end of the anti-roll bar, then refit the lower arm to the anti-roll bar. Fit the remaining plastic cover (where applicable) and the deep dished washer (colour coded yellow or black) and refit the securing nut. Do not tighten the nut at this stage. Note that the convex faces of the dished washers must face the lower arm.



3.2 Front suspension lower arm-to-crossmember pivot bolt and nut

10 Reconnect the balljoint to the hub carrier, refit the castellated nut and tighten to the specified torque. Fit a new split pin.

11 Locate the end of the lower arm in the crossmember and refit the pivot bolt, washer and nut. If necessary, push the outer rim of the roadwheel in order to line up the holes in the lower arm bush and the crossmember. Note that the pivot bolt head should face to the rear of the vehicle. Do not tighten the bolt at this stage.

12 Lower the vehicle so that its weight is resting on the roadwheels, and bounce the vehicle to settle the suspension.

13 Tighten the lower arm pivot bolt, following the procedure given in Section 2.

14 Tighten the anti-roll bar-to-lower arm securing nut to the specified torque.

15 Lower the vehicle from the ramps, if not already done.

4 Front suspension strut - removal, overhaul and refitting

Note: A spring compressor tool will be required if the strut is to be dismantled.

Removal

1 Loosen the relevant front roadwheel nuts, apply the handbrake, jack up the front of the vehicle and support on axle stands (see "Jacking and Vehicle Support").

2 Remove the roadwheel. On P100 models mark the position of the roadwheel in relation to one of the wheel studs before removal.

3 Remove the front brake caliper but do not disconnect the hydraulic hose. Support the caliper on an axle stand to avoid straining the hose.

4 Where applicable, unbolt the ABS wheel sensor from the hub carrier and detach the wire from the clip on the strut. Unplug the connector and place the sensor to one side.

5 Unscrew and remove the pinch-bolt which secures the hub carrier to the strut. Using a suitable lever, such as a cold chisel, lever the hub carrier clamp legs and wedge them apart.

6 Lever the suspension lower arm downwards to separate the hub carrier from the bottom of the strut.

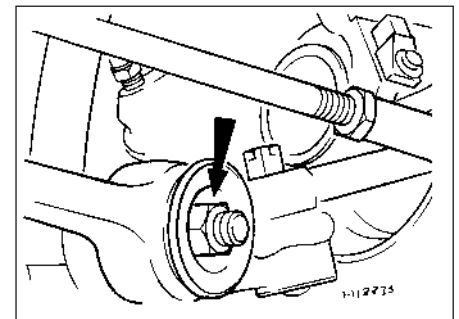

3.3 Front anti-roll bar-to-lower arm securing nut (arrowed)

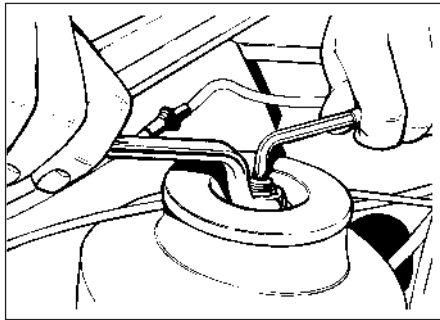

4.7 Hold the strut piston rod with a 6 mm Allen key when unscrewing the upper mounting nut

7 Working in the engine compartment, unscrew the strut upper mounting nut, at the same time supporting the strut from below. Use a 6 mm Allen key inserted in the end of the strut piston rod to prevent the rod from turning as the upper mounting nut is unscrewed (see illustration). On some models, the upper mounting nut may be fitted with a plastic cover. Note the upper mounting cup under the nut.

8 Withdraw the strut from under the wing of the vehicle.

Overhaul

9 To dismantle the strut, proceed as follows.

10 Using spring compressors, compress the coil spring. Do not attempt to compress the spring without using purpose-made spring compressors, as the spring is under considerable tension, and personal injury may occur if it is suddenly released (see illustration).

11 Hold the piston rod as described in paragraph 7, unscrew the nut from the piston

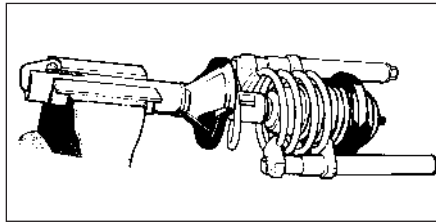

4.10 Suspension strut fitted with spring compressors

rod and remove the lower cup, bearing, spring seat, gaiter, coil spring and bump stop (see illustration).

12 Working in the engine compartment, remove the upper cup and nylon spacer, and if required prise out the rubber insulator.

13 Clean all the components and examine them for wear and damage. Check the action of the shock absorber by mounting it vertically in a vice and operating the piston rod several times through its full stroke. If any uneven resistance is evident, the shock absorber must be renewed. Renew any worn or damaged components as applicable.

Refitting

14 Reassembly and refitting is a reversal of dismantling and removal, bearing in mind the following points.

15 When reassembling, ensure that the gaiter is fitted over the bump stop, and that the ends of the coil spring are correctly located on the spring seats. Also ensure that the bearing is correctly located on the upper spring seat.

16 Fit the nylon spacer over the piston rod before fitting the strut to the top mounting.

17 Tighten all fixings to the specified torque.

18 On P100 models align the previously made marks on the roadwheel and wheel stud.

5 Front hub carrier - removal and refitting



Note: A balljoint separator tool will be required for this operation.

Removal

1 Loosen the relevant front roadwheel nuts, apply the handbrake, jack up the front of the vehicle and support on axle stands (see "Jacking and Vehicle Support").

2 Remove the roadwheel. On P100 models mark the position of the roadwheel in relation to one of the wheel studs before removal.

3 Remove the front brake caliper but do not disconnect the hydraulic hose. Support the caliper on an axle stand, or suspend it with wire from the coil spring to avoid straining the hose.

4 Mark the position of the brake disc in relation to the drive flange, and on Saloon, Hatchback and Estate models, remove the retaining screw or spire washer(s), as applicable, and remove the disc. On P100 models, unscrew the five retaining nuts and remove the wheel adapter plate and disc.

5 Where applicable, unbolt the ABS wheel sensor from the hub carrier and unplug the wiring connector. Place the sensor to one side.

6 Remove the split pin and unscrew the castellated nut securing the tie-rod end to the hub carrier. Using a balljoint separator tool, disconnect the tie-rod end from the hub carrier.

7 Repeat the procedure given in the previous paragraph for the lower arm-to-hub carrier balljoint.

8 Unscrew and remove the pinch-bolt which secures the hub carrier to the strut (see illustration). Using a suitable lever, such as a cold chisel, lever the hub carrier clamp legs and wedge them apart. Withdraw the hub carrier from the strut.

Refitting

9 Refitting is a reversal of removal, but use new split pins on the castellated nuts, and align the previously made marks on the brake disc and hub. Tighten all fixings to the specified torque.

10 On P100 models align the previously made marks on the roadwheel and wheel stud.

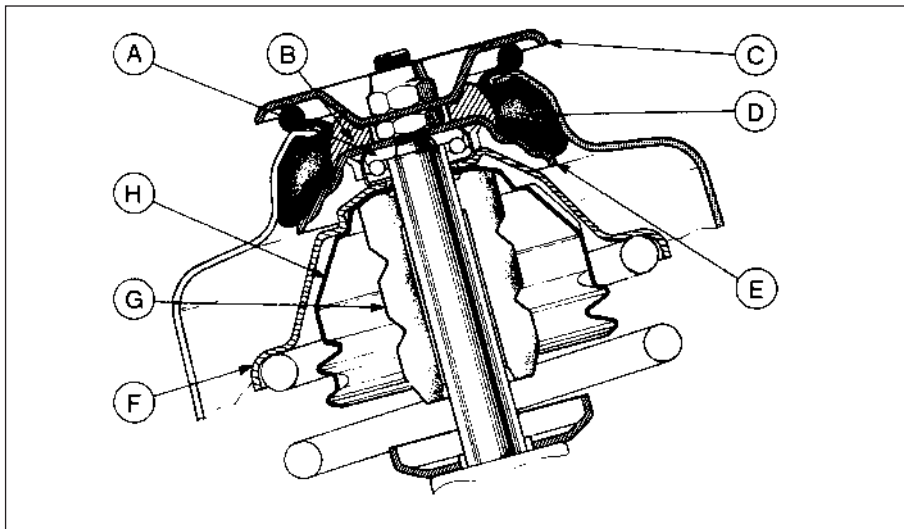

4.11 Cross-section of the front strut upper mounting

- | | | |
|----------------|--------------------|-------------|
| A Bearing | D Rubber insulator | G Bump stop |
| B Nylon spacer | E Lower cup | H Gaiter |
| C Upper cup | F Spring seat | |



5.8 Unscrewing the hub carrier-to-strut pinch-bolt

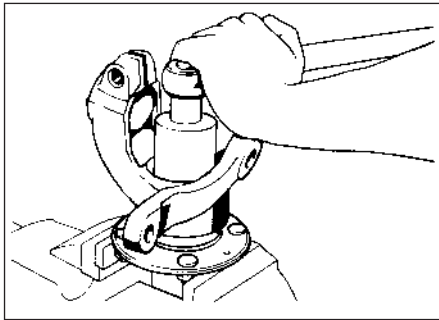

6.2 Front hub carrier mounted in vice to unscrew hub nut

6 Front wheel bearings - renewal



- 1 Remove the hub carrier.
- 2 Reverse the roadwheel nuts and screw them fully onto the studs to protect the threads, then mount the hub carrier assembly in a vice as shown (see illustration).
- 3 Prise the dust cap from the rear of the hub carrier, and unscrew the hub nut with a suitable socket. Note that on all models manufactured before late December 1982, both left and right-hand nuts have a right-hand thread, but as from this date, left-hand thread assemblies were progressively fitted to the right-hand hub carrier. The modified right-hand hub can be identified by the letter "R" stamped on its outer face, or by the colour of the hub nut nylon insert, blue indicates a normal right-hand thread, and yellow indicates a left-hand thread.
- 4 Remove the splined washer, and tap the hub carrier from the drive flange. Recover the bearing inner race and rollers from the inner end of the hub carrier (see illustration).
- 5 Prise the oil seal from the outer end of the hub carrier and remove the remaining bearing inner race and rollers.
- 6 Using a soft metal drift, drive the bearing outer races from the hub carrier, taking care not to damage the inner surface of the carrier.
- 7 Clean the hub carrier and drive flange with paraffin, wipe dry and examine for damage and wear. Note that the components are machined to very close tolerances, and the bearings are supplied in matched pairs, therefore scrupulous cleanliness must be observed.
- 8 Using a metal tube of suitable diameter, drive the new bearing outer races fully into the hub carrier. Ensure that the races are seated correctly.
- 9 Pack the inner bearing races and rollers with high-melting-point lithium-based grease, and locate the outer bearing assembly in the hub camber.
- 10 Fill the cavities between the sealing lips of the oil seal with grease, then drive it fully into the hub carrier using a block of wood or a metal tube of suitable diameter. Note that on

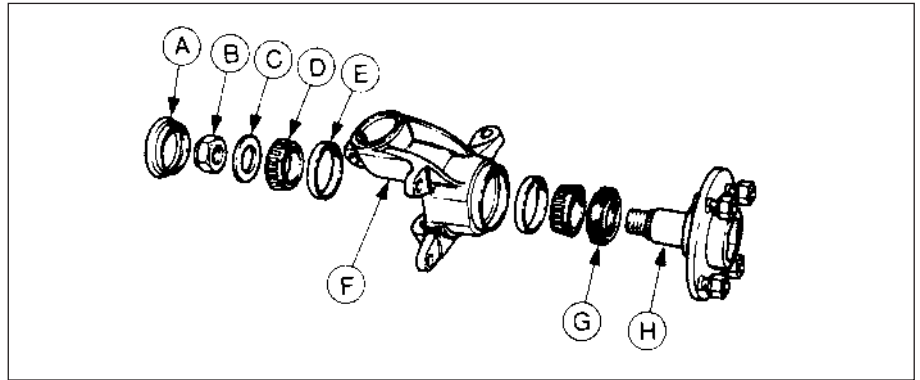

6.4 Front hub components

- | | | | |
|------------|------------------------|----------------------|----------------|
| A Dust cap | C Splined washer | E Bearing outer race | G Oil seal |
| B Hub nut | D Taper roller bearing | F Hub carrier | H Drive flange |

- early models the oil seal has a rubber casing, and this early type of seal should be replaced with the later type which has a metal casing. The oil seal should be renewed regardless of type, and a new seal of the correct type is normally supplied with the new wheel bearings.
- 11 With the drive flange mounted in a vice, as during dismantling, tap the hub carrier onto the drive flange.
 - 12 Fit the inner bearing assembly, tapping it into place with a metal tube of suitable diameter if necessary, and fit the splined washer. Note that the bearings are self-setting on assembly, and no subsequent adjustment is required.
 - 13 Refit the hub nut and tighten it to the specified torque.
 - 14 Tap the dust cap into position in the hub carrier.
 - 15 Remove the assembly from the vice, remove the roadwheel nuts, and refit the hub carrier.

- 2 Where applicable bend back the locktabs, then unscrew the two bolts securing each of the two anti-roll bar U-clamps to the vehicle underbody (see illustrations).
- 3 Ensure that the handbrake is applied, jack up the front of the vehicle and support on axle stands (see "Jacking and Vehicle Support").
- 4 Remove the anti-roll bar-to-lower arm securing nuts and recover the dished washers and plastic covers, where applicable (see illustration).
- 5 Unscrew and remove the nut, washer and pivot bolt securing one of the lower arms to the crossmember, and pull the end of the lower arm from the crossmember.
- 6 Pull the anti-roll bar from the bush in the "free" lower arm then slide the anti-roll bar from the remaining fixed lower arm. Recover the remaining dished washers and plastic covers (where applicable) from the ends of the anti-roll bar.
- 7 If necessary, the anti-roll bar compliance bushes can be renewed as described in Section 8, and the anti-roll bar U-clamp bushes can be renewed by sliding them off the ends of the bar. Note that although the U-clamp bushes are of a split design, they should not be levered open to aid fitting, and the new bushes must be slid on from the ends of the anti-roll bar. The bushes should always be renewed in pairs.

7 Front anti-roll bar - removal and refitting



Removal

- 1 To improve access, raise the front of the vehicle on ramps. Do not jack the vehicle up at this stage. Apply the handbrake.



7.2a Bend back the locktabs (arrowed) . . .



7.2b . . . unscrew the bolts and remove the anti-roll bar U-clamps

7.4 Front anti-roll bar-to-lower arm mounting

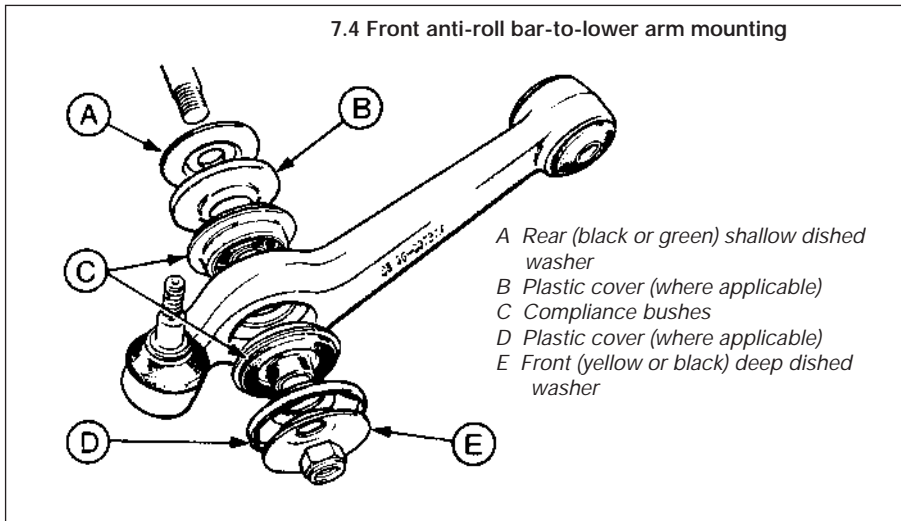

- A Rear (black or green) shallow dished washer
- B Plastic cover (where applicable)
- C Compliance bushes
- D Plastic cover (where applicable)
- E Front (yellow or black) deep dished washer

Refitting

- 8 To refit the anti-roll bar, proceed as follows.
- 9 Fit the shallow dished washers (colour coded black or green) and the plastic covers (where applicable) to the ends of the anti-roll bar, then push the anti-roll bar through the bushes in the lower arms. Fit the remaining plastic covers (where applicable) and the deep dished washers (colour coded yellow or black) and loosely fit the securing nuts. Note that the convex faces of the dished washers must face the lower arm. Do not tighten the nuts fully at this stage.
- 10 Locate the "free" lower arm inner pivot bush in the crossmember, and refit the pivot bolt, washer and nut. If necessary, push the outer rim of the roadwheel in order to line up the holes in the lower arm bush and the crossmember. Note that the pivot bolt head should face to the rear of the vehicle. Do not tighten the bolt at this stage.
- 11 Lower the vehicle so that its weight is resting on the roadwheels.
- 12 Refit the anti-roll bar U-clamps to the vehicle underbody. Note that various different types of clamping components have been used during production, and if any of the components are to be renewed, it is important to retain the old components for identification when ordering new parts. The same type of clamp assembly must be used on both sides of the vehicle. Tighten the bolts evenly on each clamp to the specified torque. Where applicable, secure the bolts with the locktabs.
- 13 Bounce the vehicle to settle the suspension, then tighten the lower arm pivot bolt, following the procedure given in Section 2.
- 14 Tighten the anti-roll bar-to-lower arm securing nuts to the specified torque.
- 15 Lower the vehicle from the ramps, if not already done.

8 Front anti-roll bar-to-lower arm compliance bushes - renewal

Note: The compliance bushes must be renewed in vehicle sets, therefore the bushes on both sides of the vehicle must be renewed at the same time. If plastic covers were not originally fitted between the dished washers and the bushes, suitable covers should be obtained for fitting during reassembly.

- 1 Remove the anti-roll bar.
- 2 Using a thin-bladed chisel or screwdriver, carefully prise out the compliance bushes from the lower arms.
- 3 Tap the new bushes into place using a suitable socket or tube drift (see illustration).
- 4 Some vehicles may have small rubber spacer washers fitted to the ends of the anti-roll bar, and these should be discarded on reassembly.
- 5 Refit the anti-roll bar.

9 Front suspension lower arm inner pivot bush - renewal

- 1 To improve access, raise the front of the vehicle on ramps. Apply the handbrake.
- 2 Unscrew and remove the nut, washer and pivot bolt securing the relevant lower arm to the crossmember.
- 3 Remove the anti-roll bar-to-lower arm securing nut and recover the dished washer and plastic cover (where applicable).
- 4 Ensure that the handbrake is applied, jack up the front of the vehicle and support on axle stands (see "Jacking and Vehicle Support").
- 5 Pull the inner end of the lower arm from the crossmember.
- 6 The pivot bush can now be removed from the lower arm using a long bolt with nut, washers and a suitable metal tube.
- 7 Lubricate the new bush with soapy water, and fit with a single continuous action to avoid

deformation of the bush, again using the bolt, nut, washers and tube.

8 Locate the end of the lower arm in the crossmember, and refit the pivot bolt, washer and nut. If necessary, push the outer rim of the roadwheel in order to line up the holes in the lower arm bush and the crossmember. Note that the pivot bolt head should face to the rear of the vehicle. Do not tighten the bolt at this stage.

9 Refit the plastic cover, dished washer (where applicable), and nut to the end of the anti-roll bar. Do not tighten the nut at this stage.

10 Lower the vehicle so that its weight is resting on the roadwheels, and bounce the vehicle to settle the suspension.

11 Tighten the lower arm pivot bolt, following the procedure given in Section 2.

12 Tighten the anti-roll bar-to-lower arm securing nut to the specified torque.

13 Lower the vehicle from the ramps, if not already done.

10 Rear suspension and final drive unit assembly (Saloon, Hatchback and Estate models) - removal and refitting

Note: From May 1986, revised final drive unit rear mounting bolts have been used in production. Whenever the earlier type of bolts are removed, they should be discarded and the later type fitted. The earlier bolts are coloured blue, and the later type bolts are coloured gold.

Removal

- 1 Jack up the vehicle and support on axle stands (see "Jacking and Vehicle Support"). It is only strictly necessary to jack up the rear of the vehicle, but this provides only limited access. Note that the axle stands should be positioned under the side members.
- 2 Remove the rear section of the exhaust system - i.e. from the joint.
- 3 Remove the propeller shaft.
- 4 Disconnect the handbrake equaliser from the operating rod by removing the circlip and

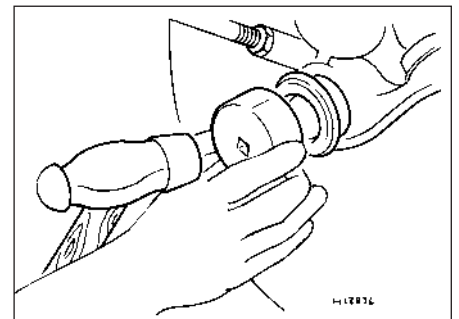

8.3 Tapping a front anti-roll bar-to-lower arm compliance bush into position

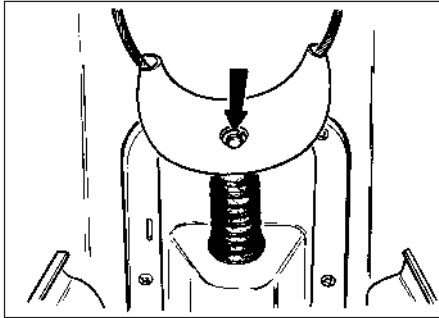

10.4 Handbrake equaliser-to-operating rod circlip and pivot pin (arrowed)

pivot pin. Take care not to lose the components (see illustration).

5 Remove the brake cable sheaths from their brackets on the vehicle underbody.

6 Unscrew the brake pipes from the brake hoses at the brackets on the vehicle underbody. Plug the ends of the pipes and hoses to prevent leakage and dirt ingress, then detach the hoses from the brackets by removing the U-shaped retaining clips (see illustration).

7 Where applicable, disconnect the ABS sensors, and detach the leads from the clips on the lower arms.

8 Place suitable blocks beneath the rear wheels, then lower the vehicle so that the rear coil springs are lightly loaded. Reposition the axle stands under the side members.

9 Support the final drive unit with a jack, using an interposed block of wood to spread the load.

10 Where applicable, unscrew and remove the two anti-roll bar mountings from the underbody.

11 Unscrew and remove the three bolts securing each of the front guide plates to the underbody and the suspension crossmember (see illustration). Where applicable, bend back the lockwasher tabs on the larger bolts.

12 Unscrew and remove the four bolts securing the final drive unit rear mounting to the underbody. Note the location and number of any shims which may be fitted (see illustration).

13 Working inside the rear of the vehicle, disconnect the shock absorber upper mountings. On Saloon and Hatchback

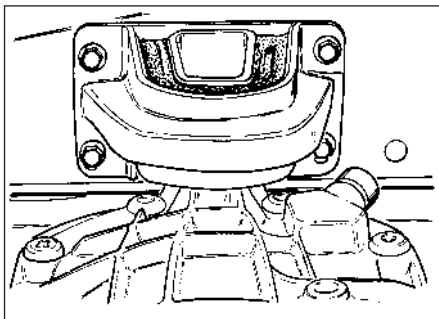

10.12 Final drive unit-to-underbody rear mounting

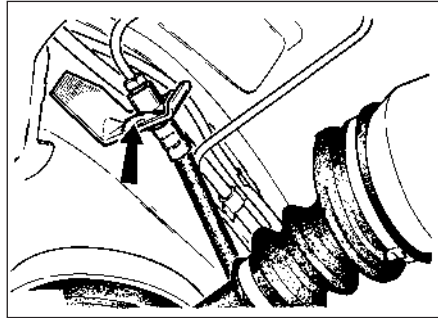

10.6 Rear underbody brake pipe bracket - U-shaped hose retaining clip arrowed

models, access is gained by removing the trim covers behind the side cushions. Each cover is secured by two self-tapping screws, and the shock absorber is secured by a bolt and nut. On Estate models, fold down the rear seat backrest, fold back the floor covering and remove the front section of the luggage compartment floor, which is secured with 12 self-tapping screws. Remove the nut and washer from the shock absorber.

14 Using a jack and a wooden beam positioned beneath the longitudinal underbody side members, raise the rear of the vehicle until the rear suspension and final drive unit assembly can be withdrawn from under the vehicle.

15 If desired, the assembly can be dismantled with reference to the relevant Sections of this Chapter and Chapter 9.

Refitting

16 Refitting is a reversal of removal, bearing in mind the following points.

17 Where applicable, secure the larger front guide plate bolts by bending up the lockwasher tabs.

18 Ensure that the coil springs are located correctly on their seats on the vehicle underbody.

19 When refitting the final drive rear mounting to the underbody, refit any shims in their original noted positions, and fit the bolts with reference to the note at the beginning of this Section.

20 Tighten all fixings to the specified torque.

21 On completion, bleed the brakes and adjust the handbrake. With the vehicle level, check the final drive unit oil level.



11.4 Brake pipe bracket on lower arm. U-shaped retaining clip arrowed

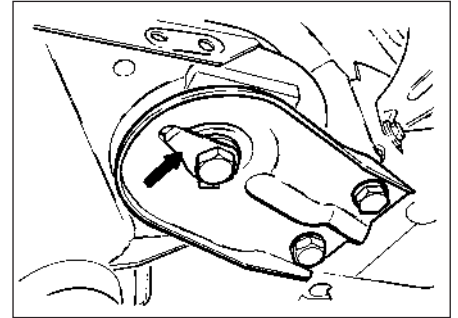

10.11 Rear suspension front guide plate - lockwasher arrowed

11 Rear suspension lower arm (Saloon, Hatchback and Estate models) - removal and refitting

Models with rear drum brakes

Removal

1 Chock the front wheels, jack up the rear of the vehicle and support on axle stands placed under the side members.

2 Remove the relevant driveshaft.

3 Remove the handbrake cable from the clip on the lower arm.

4 Unscrew the brake pipe from the brake hose at the bracket on the lower arm. Plug the ends of the pipe and hose to prevent leakage and dirt ingress, then detach the hose from the bracket by removing the U-shaped retaining clip (see illustration).

5 Unscrew the brake pipe from the wheel cylinder on the brake backplate and plug the end of the pipe and the cylinder to prevent leakage and dirt ingress.

6 Unscrew the bolts securing the brake backplate to the lower arm and tie the backplate to one side.

7 Where applicable, prise the anti-roll bar connecting strap from the lower arm.

8 Support the lower arm on a jack, and raise it slightly to place the coil spring under load.

9 Remove the shock absorber.

10 Unscrew and remove the three bolts securing the front guide plate to the underbody and the suspension crossmember (see illustration). Where applicable, bend back the lockwasher tab(s) on the larger bolt.

11 Lower the lower arm, and remove the coil spring and rubber cup.

12 Note the orientation of the two lower arm-to-crossmember pivot bolts and nuts, then unscrew and remove them and withdraw the lower arm from under the vehicle (see illustration).

13 If the lower arm is to be renewed, unclip the brake pipe, and refit to the new arm.

14 If required, the pivot bushes may be renewed using a long bolt, nut, washers and a suitable metal tube. Lubricate the new bushes with soapy water before fitting.



11.10 Rear suspension front guide plate

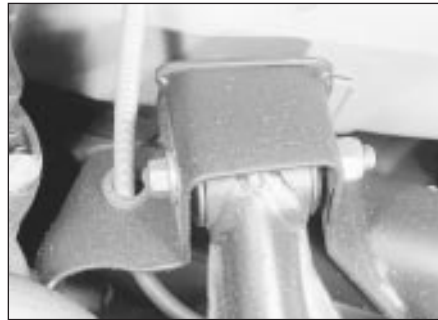

11.12 Lower arm-to-crossmember inner pivot

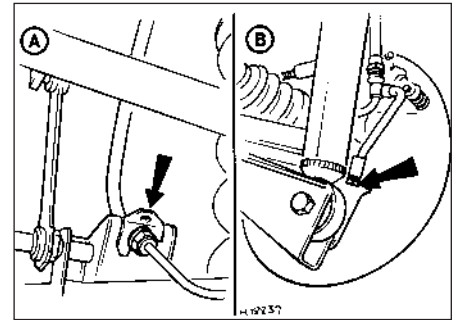

11.23 Rear suspension lower arm brake pipe brackets (arrowed)

A Left-hand bracket B Right-hand bracket

Refitting

15 Refitting is a reversal of removal, bearing in mind the following points.

16 Where applicable, secure the larger front guide plate bolt by bending up the lockwasher tab(s).

17 Before tightening the lower arm-to-crossmember pivot bolts and nuts, lower the vehicle so that its weight is resting on the roadwheels, and bounce the vehicle to settle the suspension. Ensure that the bolts are orientated as noted during removal.

18 On completion, bleed the brakes and adjust the handbrake.

Models with rear disc brakes

Note: A suitable puller will be required to remove the drive flange, and a new rear hub nut must be used on reassembly.

Removal

19 With the vehicle resting on its wheels, loosen the rear hub nut. A suitable extension bar will be required, as the nut is extremely tight. Note that the left-hand nut has a left-hand thread, ie it is undone in a clockwise direction. Before loosening the nut, ensure that the handbrake is applied, and chock the relevant rear wheel.

20 Loosen the rear roadwheel nuts on the side concerned, chock the front wheels, jack up the rear of the car and support on axle stands placed under the side members.

21 Remove the rear roadwheel.

22 Remove the rear section of the exhaust system - ie from the joint.

23 Unscrew the brake pipe from the brake hose at the bracket on the lower arm (see illustration). Plug the ends of the pipe and hose to prevent leakage and dirt ingress, then detach the hose from the bracket by removing the U-shaped retaining clip.

24 Remove the handbrake cable from the clip on the lower arm.

25 Unbolt the brake caliper and tie it to one side, taking care not to strain the brake hose.

26 Mark the position of the brake disc in relation to the hub, remove the retaining spire washer(s), and remove the disc.

27 Disconnect the driveshaft from the hub assembly by unscrewing the six securing bolts. Support the driveshaft to avoid straining

the joints, or alternatively, unbolt it from the final drive unit at the inboard end and remove the driveshaft from the vehicle. At all times, avoid bending the driveshaft joints to excessive angles, and do not allow the shaft to hang down from one end.

28 Unscrew and remove the rear hub nut, and using a puller pull off the drive flange.

29 Unscrew the four bolts securing the hub carrier and splash shield to the lower arm. Remove the hub carrier and splash shield. Note that the stub axle is retained in the hub carrier.

30 Disconnect the ABS sensor, and detach the lead from the clip on the lower arm.

31 Remove the propeller shaft.

32 Proceed as shown in paragraphs 7 to 14 inclusive.

Refitting

33 Refitting is a reversal of removal, bearing in mind the following points.

34 Where applicable, secure the larger front guide plate bolt by bending up the lockwasher tabs.

35 When refitting the hub carrier to the lower arm note that there are two types of bolts used. The two types of bolt must not be mixed on a vehicle, but can be changed in complete sets for the alternative type. A complete set is eight bolts, four each side. Note that the two types of bolt have different torque wrench settings. When renewing the wheel bearings a suitable puller will be required to remove the drive flange, and a new rear hub nut must be used on reassembly.

36 When refitting the drive flange to the hub assembly, use a new hub nut, and leave tightening until the vehicle is resting on its wheels. Apply the handbrake and chock the relevant rear wheel when tightening the nut.

37 When refitting the brake disc, align the previously made marks on disc and hub.

38 Before tightening the lower arm-to-crossmember pivot bolts and nuts, lower the vehicle so that its weight is resting on the roadwheels, and bounce the vehicle to settle the suspension. Ensure that the bolts are orientated as noted during removal.

39 On completion, bleed the brakes and adjust the handbrake.

12 Rear shock absorber - removal and refitting



Saloon and Hatchback models

1 With the weight of the vehicle resting on the roadwheels, work under the vehicle to unscrew and remove the shock absorber lower mounting bolt and nut from the relevant lower arm (see illustration). If desired, the rear of the vehicle can be raised on ramps to improve access.

2 Working inside the rear of the vehicle, remove the trim cover behind the side cushion. The cover is secured by two self-tapping screws (see illustrations).



12.1 Rear shock absorber lower mounting - Saloon and Hatchback models



12.2a Remove the trim cover . . .



12.2b . . . for access to the rear shock absorber upper mounting

- 3 With an assistant supporting the shock absorber from below, unscrew and remove the upper mounting bolt and nut. Withdraw the shock absorber from under the vehicle.
- 4 Refitting is a reversal of removal. Tighten the mounting bolts securely.

Estate models

Note: On models fitted with heavy duty Nivomat shock absorbers, follow the procedure given in Section 13, as the shock absorber and coil spring are an integrated unit.

- 5 With the weight of the vehicle resting on the roadwheels, work under the vehicle to unscrew and remove the two shock absorber lower mounting bolts from the relevant lower arm (see illustration). If desired, the rear of the vehicle can be raised on ramps to improve access.
- 6 Working inside the rear of the vehicle, fold down the rear seat backrest, fold back the floor covering and remove the front section of the luggage compartment floor, which is secured with 12 self-tapping screws.
- 7 With an assistant supporting the shock absorber from below, unscrew and remove the upper mounting nut and washer (see illustration). Withdraw the shock absorber from under the vehicle.
- 8 Refitting is a reversal of removal. Tighten the mounting bolts and nut securely.

P100 models

- 9 With the weight of the vehicle resting on the roadwheels, work under the vehicle to unscrew and remove the shock absorber lower mounting nut, washer, and rubber insulator. If desired, the rear of the vehicle can be raised on ramps to improve access.

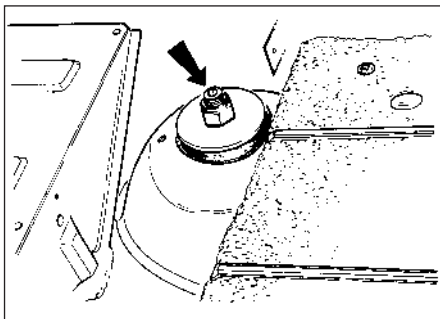

12.7 Rear shock absorber upper mounting (arrowed) - Estate models

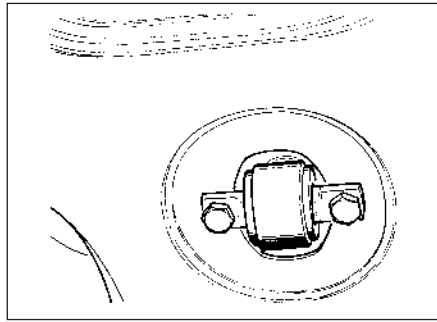

12.5 Rear shock absorber lower mounting bolts - Estate models

- 10 Unscrew and remove the top mounting bolt, nut and washer from the chassis crossmember. Withdraw the shock absorber upwards.
- 11 Refitting is a reversal of removal. Tighten the mounting bolt and nut securely.

13 Rear coil spring (Saloon, Hatchback and Estate models) - removal and refitting

Models with rear drum brakes

- 1 Remove the relevant driveshaft.
- 2 Unscrew the brake pipe from the brake hose at the bracket on the vehicle underbody. Plug the ends of the pipe and hose to prevent leakage and dirt ingress.
- 3 Where applicable, prise the anti-roll bar connecting strap from the lower arm.
- 4 Support the lower arm on a jack, and raise it slightly to place the coil spring under load.
- 5 On Saloon and Hatchback models, unscrew and remove the shock absorber lower mounting bolt and nut from the lower arm.
- 6 On Estate models fitted with standard shock absorbers, remove the shock absorber as described in Section 12. On Estate models fitted with heavy duty Nivomat shock absorbers, disconnect the upper and lower mountings.
- 7 Unscrew and remove the three bolts securing the front guide plate to the underbody and the suspension crossmember. Where applicable, bend back the lockwasher tab(s) on the larger bolt.

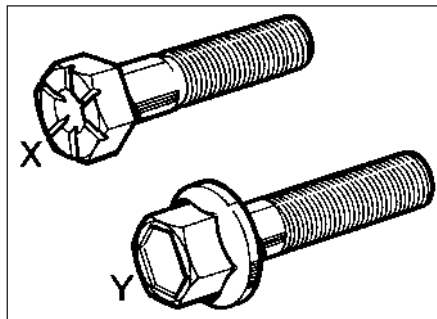

14.1a Alternative types of rear hub carrier-to-lower arm securing bolts

- 8 Lower the lower arm, and remove the coil spring, or coil spring/heavy duty shock absorber as applicable, and the rubber cup.
- 9 Refitting is a reversal of removal, bearing in mind the following points.
- 10 Where applicable, secure the larger front guide plate bolt by bending up the lockwasher tab(s).
- 11 Refit the driveshaft.
- 12 On completion, bleed the brakes.

Models with rear disc brakes

- 13 Chock the front wheels, jack up the rear of the vehicle and support on axle stands placed under the side members.
- 14 Disconnect the driveshaft from the hub assembly by unscrewing the six securing bolts. Support the driveshaft to avoid straining the joints, or alternatively, unbolt it from the final drive unit at the inboard end and remove the driveshaft from the vehicle. At all times, avoid bending the driveshaft joints to excessive angles, and do not allow the shaft to hang down from one end.
- 15 Proceed as shown in paragraphs 2 to 8 inclusive.
- 16 Refitting is a reversal of removal. Where applicable, secure the larger front guide plate bolt by bending up the lockwasher tab(s), and on completion, bleed the brakes.

14 Rear wheel bearings - renewal

Saloon, Hatchback and Estate models

With rear drum brakes

Note: There are two types of bolts used to secure the rear hub carrier to the lower arm (see illustration). The two types of bolt must not be mixed on a vehicle, but can be changed in complete sets for the alternative type. A complete set is eight bolts, four each side. Note that the two types of bolt have different torque wrench settings. When renewing the wheel bearings a suitable puller will be required to remove the drive flange, and a new rear hub nut must be used on reassembly.

- 1 Loosen the rear hub nut with the vehicle resting on its wheels. On early models, relieve the staking before loosening the nut (see illustration). Later models use self-locking



14.1b On early models relieve the staking (arrowed) on the rear hub nut

nuts, and it is important to note that where this type of nut is fitted, the left-hand nut has a left-hand thread, ie. it is undone in a clockwise direction. Before loosening the nut, ensure that the handbrake is applied, and chock the relevant rear wheel. A suitable extension bar will be required, as the nut is extremely tight.

2 Loosen the rear roadwheel nuts on the side concerned, chock the front wheels, and jack up the rear of the vehicle and support on axle stands (see "Jacking and Vehicle Support"). Remove the rear roadwheel.

3 Remove the brake drum retaining spire washer(s) from the wheel stud(s) and remove the brake drum. Ensure that the handbrake is released before removing the brake drum, otherwise the drum will be held in place by the clamping action of the brake shoes.

4 Remove the two nylon fasteners, and remove the plastic shield from the rear of the brake backplate (see illustration).

5 Unscrew and remove the rear hub nut.

6 Using a suitable puller, pull the drive flange from the end of the driveshaft (see illustration).

7 Unscrew and remove the four bolts securing the hub carrier and brake backplate to the lower arm (see illustration). Remove the hub carrier, whilst supporting the driveshaft. Support the driveshaft by placing axle stands underneath it, or by securing with string to the underbody. Note that the driveshaft joints should not be allowed to deflect through an angle exceeding 13°.

8 Refit the brake backplate with the four securing bolts to avoid straining the brake pipe.

9 With the hub carrier removed, the bearings can be renewed as follows (see illustration).

10 Prise the inner and outer oil seals from the hub carrier using a suitable screwdriver, and withdraw the taper roller bearings.

11 Using a soft metal drift, drive the bearing outer races from the hub carrier, taking care not to damage the inner surface of the carrier.



14.4 Remove the nylon fasteners (arrowed) to free the plastic shield from the brake backplate



14.6 Pull the drive flange from the end of the driveshaft

12 Clean the hub carrier and drive flange with paraffin, wipe dry and examine for damage and wear. Note that the components are machined to very close tolerances, and the bearings are supplied in matched pairs, therefore scrupulous cleanliness must be observed.

13 Using a metal tube of suitable diameter, drive the new bearing outer races fully into the hub carrier. Ensure that the races are seated correctly.

14 Pack the inner bearing races and rollers with high-melting-point lithium-based grease, and locate the outer bearing assembly in the hub carrier.

15 Fill the cavities between the sealing lips of the oil seal with grease, then drive it fully into the hub carrier using a block of wood or a metal tube of suitable diameter. Note that on early models the oil seal has a rubber casing, and this type of seal should be replaced with the later type which has a metal casing. The oil seal should be renewed regardless of type, and a new oil seal of the correct type is normally supplied with the new wheel bearings.

16 Repeat the procedure shown in paragraphs 14 and 15 for the outer bearing and oil seal.

17 Fit the drive flange to the hub carrier in order to centralise the bearings, then remove the securing bolts from the brake backplate, and using a soft-faced mallet, drive the drive flange/hub carrier assembly onto the end of the driveshaft.

18 Further refitting is a reversal of removal, bearing in mind the following points.

19 Refit the hub carrier/brake backplate-to-lower arm securing bolts with reference to the note at the beginning of this sub-Section.

20 Fit a new rear hub nut of the correct type, and tighten it with the vehicle resting on its roadwheels. Apply the handbrake and chock the relevant rear wheel. If a staked type nut is used, lock the nut by staking its outer ring into the groove in the driveshaft.

With rear disc brakes

Note: See note at the beginning of this Section

21 Loosen the rear hub nut with the vehicle resting on its wheels. Note that the left-hand nut has a left-hand thread, ie. it is undone in a clockwise direction. Before loosening the nut, ensure that the handbrake is applied, and chock the relevant rear wheel. A suitable extension bar will be required, as the nut is extremely tight.

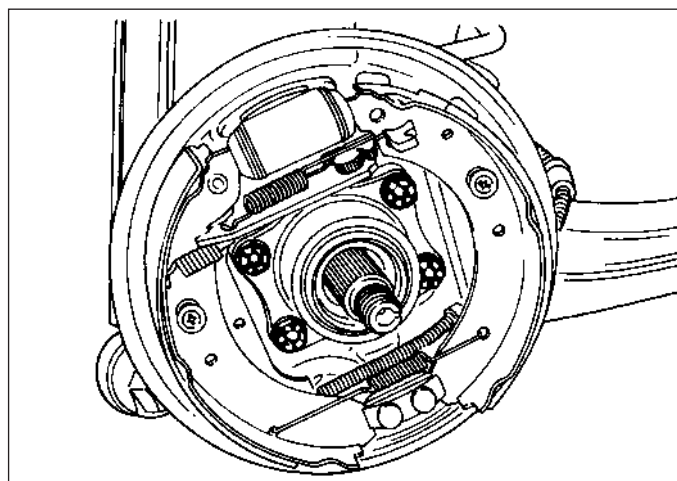

14.7 Rear hub carrier/brake backplate-to-lower arm securing bolts

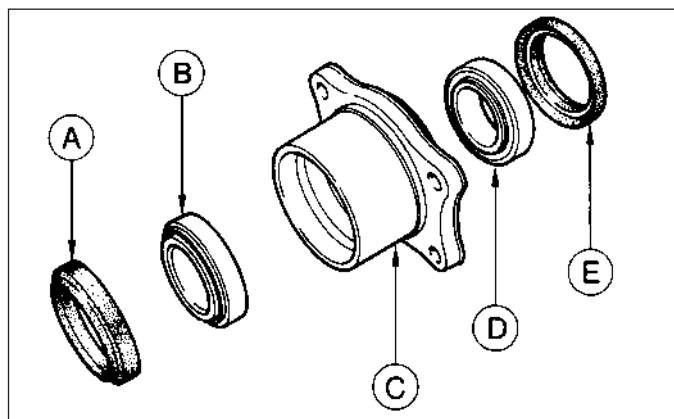

14.9 Rear hub carrier components - Saloon, Hatchback and Estate models

- A Outer oil seal
- B Outer bearing
- C Hub carrier
- D Inner bearing
- E Inner oil seal

22 Loosen the rear roadwheel nuts on the side concerned, chock the front wheels, and jack up the rear of the vehicle and support on axle stands. Remove the roadwheel and release the handbrake.

23 Unbolt the brake caliper carrier bracket and support the caliper on an axle stand, taking care not to strain the flexible hose.

24 Mark the position of the brake disc in relation to the drive flange, remove the retaining spire washer(s), and remove the disc.

25 Unscrew and remove the rear hub nut, and using a puller, pull off the drive flange.

26 Unscrew the four bolts securing the hub carrier and splash shield to the lower arm. Remove the hub carrier and splash shield, whilst supporting the driveshaft. Support the driveshaft by placing axle stands underneath it, or by securing with string to the underbody. Avoid bending the driveshaft joints to excessive angles, and do not allow the shaft to hang down from one end.

27 With the hub carrier removed, the bearings can be renewed as described in paragraphs 10 to 16 of this Section.

28 Fit the drive flange to the hub carrier in order to centralise the bearings, then using a soft-faced mallet, drive the drive flange/hub carrier assembly onto the end of the stub axle. Do not forget to fit the splash shield.

29 Further refitting is a reversal of removal, bearing in mind the following points.

30 Refit the hub carrier/splash shield-to-lower arm securing bolts with reference to the note at the beginning of this sub-Section.

31 When refitting the brake disc, align the previously made marks on disc and drive flange.

32 Fit a new rear hub nut of the correct type, and tighten it with the vehicle resting on its roadwheels. Apply the handbrake and chock the relevant rear wheel.

P100 models

Note: A new rear hub nut must be used on reassembly.

33 Remove the relevant driveshaft.

34 Relieve the staking on the rear hub nut, and using a 50 mm socket and an extension bar, unscrew the nut. Note that the nut is extremely tight.

35 Pull off the hub, and remove the O-ring and spacer sleeve from the recess in the hub (see illustration).

36 Prise the oil seal from the rear of the hub using a screwdriver.

37 Using a block of wood, or a suitable metal tube inserted from the rear of the hub, tap out the ball-bearing.

38 Clean the hub with paraffin, wipe dry and examine for damage and wear.

39 Using a metal tube of suitable diameter, resting on the bearing outer race only, tap the new bearing into the hub. Ensure that the bearing is correctly seated.

40 Carefully fit a new oil seal to the rear of the hub, using a suitable metal tube.

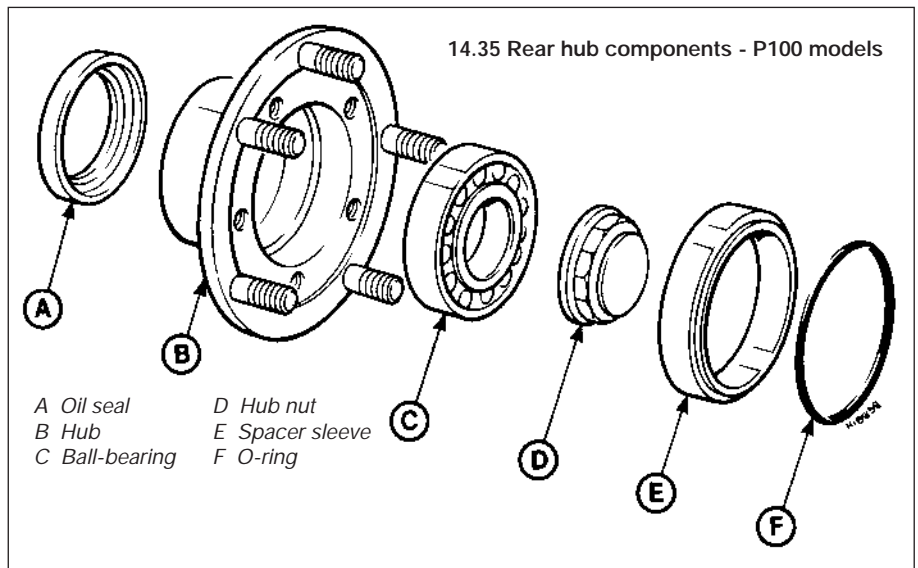

41 Refitting is a reversal of removal, bearing in mind the following points.

42 Fit a new rear hub nut, and stake in position after tightening to the specified torque.

15 Rear suspension front mounting (Saloon, Hatchback and Estate models) - renewal

1 Chock the front wheels, jack up the rear of the vehicle and support on axle stands placed under the side members.

2 Unscrew and remove the three bolts securing the relevant front guide plate to the underbody and the suspension crossmember. Where applicable, bend back the lockwasher tab(s) on the larger bolt.

3 Using a length of wood, lever the suspension crossmember downwards a few inches from the underbody, and insert the wood as a wedge.

4 Using a tool similar to the Ford special tool shown (see illustration), or a long bolt with nut, washers and a suitable metal tube, pull the mounting rubber from the crossmember.

5 Lubricate the new mounting rubber with soapy water, and use the tool described in the previous paragraph to press the rubber into the crossmember.

6 Further refitting is a reversal of removal. Where applicable, secure the larger front guide plate bolt by bending up the lockwasher tab(s).

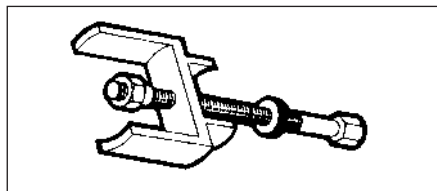

15.4 Ford special tool 15-014 for removing rear suspension front mounting rubber

16 Rear suspension/final drive unit rear mounting (Saloon, Hatchback and Estate models) - renewal

Note: From May 1986, revised rear suspension/final drive unit rear mounting bolts have been used in production. Whenever the earlier type of bolts are removed, they should be discarded and the later type fitted. The earlier bolts are coloured blue, and the later type bolts are coloured gold.

1 Chock the front wheels, jack up the rear of the vehicle and support on axle stands placed under the side members.

2 Support the final drive unit with a jack, using an interposed block of wood to spread the load.

3 Unscrew and remove the four bolts securing the mounting to the underbody. Note the location and number of any shims which may be fitted.

4 Lower the final drive unit sufficiently to enable the mounting to be unbolted from the final drive unit rear cover (see illustration).

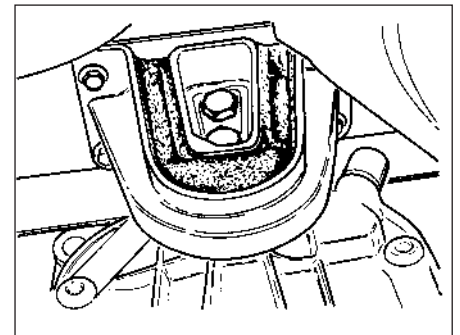

16.4 Rear suspension/final drive unit rear mounting-to-final drive unit rear cover bolts

5 Refitting is a reversal of removal, with reference to the note at the beginning of this Section. Refit any shims in their original noted positions, and tighten all bolts to the specified torque.

17 Rear anti-roll bar (Saloon, Hatchback and Estate models) - removal and refitting

Removal

- 1 Loosen the rear roadwheel nuts, chock the front wheels, jack up the rear of the vehicle and support on axle stands placed under the side members.
- 2 Prise off the straps which connect the anti-roll bar to the suspension lower arms (see illustration).
- 3 Unbolt the two securing brackets from the underbody, and remove the anti-roll bar (see illustration).
- 4 The connecting straps can be prised from the ends of the anti-roll bar, and the underbody mounting brackets and rubbers, which are of a split design, can be pulled off.
- 5 When fitting new mounting components, lubricate the rubber parts with soapy water to ease assembly.

Refitting

- 6 Refitting is a reversal of removal. Tighten the anti-roll bar-to-underbody securing bolts to the specified torque.



17.2 Anti-roll bar-to-lower arm connecting strap

- 2 Support the rear axle with a jack, using an interposed block of wood to spread the load.
- 3 Remove the propeller shaft.
- 4 Remove the securing circlip and the pivot pin, and detach the handbrake equaliser from the linkage on the underbody.
- 5 Remove the handbrake cables from the clips on the underbody, and from the brackets on the crossmember. To remove the cables from the crossmember, remove the U-shaped retaining clips. Note that the cable adjuster is secured to the right-hand crossmember bracket. Ensure that the handbrake is released before attempting to disconnect any part of the mechanism.
- 6 Unscrew the brake pipe from the brake hose on the right-hand side of the chassis crossmember. Plug the ends of the pipe and hose to prevent leakage and dirt ingress, then detach the hose from the crossmember by removing the U-shaped retaining clip (see illustration).

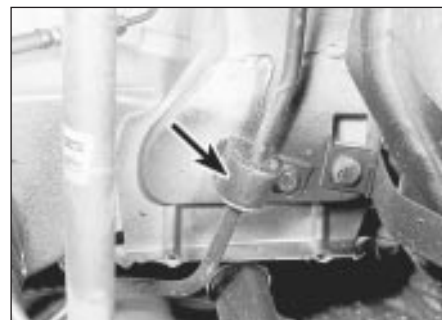

17.3 Anti-roll bar-to-underbody securing bracket

vehicle, guiding the handbrake cables over the exhaust system.

Refitting

- 13 Refitting is a reversal of removal, bearing in mind the following points.
- 14 Do not fully tighten the leaf spring mounting bolts or the spring shackle-to-underbody bolts until the weight of the vehicle is resting on the roadwheels.
- 15 Renew all self-locking nuts and spring washers.
- 16 On completion, check the brake load apportioning valve adjustment and the handbrake adjustment. Bleed the rear brake circuit and check the axle oil level.

18 Rear suspension and axle assembly (P100 models) - removal and refitting

Note: All self-locking nuts and spring washers must be renewed on reassembly.

Removal

- 1 Chock the front wheels, jack up the rear of the vehicle and support on axle stands placed under the side members. Note that a loaded vehicle must not be jacked under the differential casing.

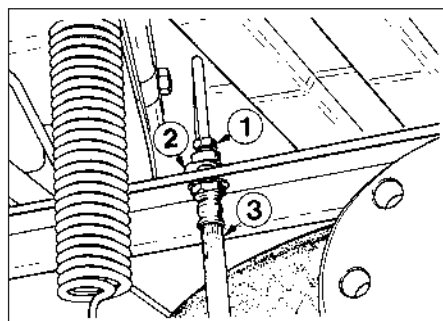

18.6 Brake pipe-to-hose connection on right-hand side of chassis crossmember - P100 models

- 1 Brake pipe
- 2 U-shaped clip
- 3 Brake hose



18.7 Remove the split pin (arrowed) from the brake load apportioning valve lever

19 Rear suspension leaf spring (P100 models) - removal and refitting

Note: All self-locking nuts and spring washers must be renewed on reassembly.

Removal

- 1 Chock the front wheels, jack up the rear of the vehicle and support on axle stands placed under the side members. Note that a loaded vehicle must not be jacked under the differential casing.
- 2 Support the relevant side of the rear axle with a jack, using an interposed block of wood under the axle tube to spread the load.
- 3 Unscrew the nuts, and remove the two U-bolts on each side of the vehicle which secure the axle to the leaf springs (see illustration). Note that there is no need to



19.3 Unscrew the nuts (arrowed) from the rear axle-to-leaf spring U-bolts

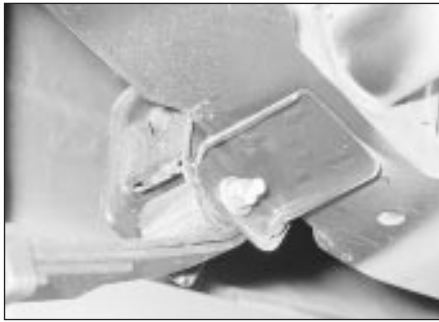

19.4 Leaf spring front bracket

disconnect the shock absorber from the U-bolt counterplate.

4 Unbolt the leaf spring from the front bracket on the underbody (see illustration).

5 Loosen the spring shackle-to-underbody bolt, then unbolt the leaf spring from the spring shackle and remove the spring (see illustration).

Refitting

6 Refitting is a reversal of removal, bearing in mind the following points.

7 Do not fully tighten the leaf spring mounting bolts or the spring shackle-to-underbody bolt until the weight of the vehicle is resting on its roadwheels.

8 Renew all self-locking nuts and spring washers.

9 Align the axle on the leaf spring so that the locating pin on the spring engages with the corresponding hole in the axle. Similarly ensure that the U-bolt counterplate engages with the locating pin on the leaf spring.

20 Rear suspension leaf spring shackle (P100 models) - removal and refitting

Note: All self-locking nuts and spring washers must be renewed on reassembly.

Removal

1 Chock the front wheels, jack up the rear of the vehicle and support on axle stands placed under the side members. Note that a loaded vehicle must not be jacked under the differential casing.



22.2 Prise off the steering wheel trim insert and disconnect the horn electrical lead

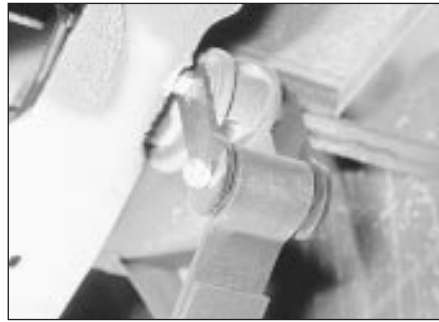

19.5 Leaf spring shackle

2 Support the relevant side of the rear axle with a jack, using an interposed block of wood under the axle tube to spread the load.

3 Unscrew and remove the spring shackle-to-underbody bolt and the leaf spring-to-spring shackle bolt, and remove the shackle components.

4 Examine the components for wear and damage and renew as necessary.

Refitting

5 Refitting is a reversal of removal, but renew all self-locking nuts and spring washers, and do not fully tighten the bolts until the weight of the vehicle is resting on its roadwheels.

21 Rear suspension leaf spring bush (P100 models) - renewal

Note: All self-locking nuts and spring washers must be renewed on reassembly.

1 Proceed as described in Section 19, paragraphs 1 to 3 inclusive.

2 Unbolt the relevant end of the leaf spring, and lower it to gain access to the bush. Note that if the shackle end of the spring is unbolted, the shackle-to-underbody bolt should be loosened in order to aid refitting.

3 The bush can be removed using a long bolt with nut, washers and a suitable metal tube.

4 Lubricate the new bush with soapy water and fit using the bolt, nut, washers and tube.

5 Proceed as described in Section 19, paragraphs 6 to 9 inclusive.

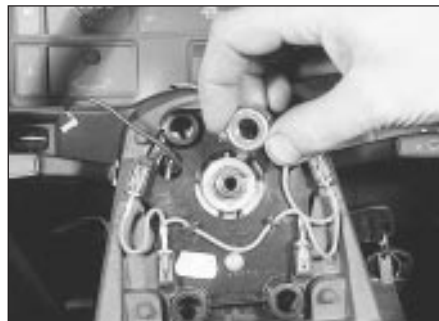

22.4 Removing the steering wheel retaining nut

22 Steering wheel - removal and refitting

Removal

1 Set the front wheels in the straight-ahead position.

2 Prise the trim insert from the centre of the steering wheel, and where applicable, disconnect the horn electrical lead(s) (see illustration).

3 Insert the ignition key and check that the steering lock is disengaged.

4 Unscrew the retaining nut and withdraw the steering wheel from the hexagon shaped inner column (see illustration). If the wheel is tight on the inner column, sit in the driver's seat and tap the wheel from behind with the palms of the hands (but screw the nut back on two or three turns for safety).

Refitting

5 Refitting is a reversal of removal, but check that the lug on the direction indicator cam is aligned with the cut-out in the steering wheel, and make sure that the direction indicator switch is in the neutral position. Tighten the retaining nut to the specified torque.

23 Steering wheel - centralising

1 This operation is for correcting small errors in steering wheel centralisation - up to 60°. For larger errors, remove the steering wheel and make a rough correction by repositioning the wheel on refitting.

2 Drive the vehicle in a straight line on a level surface. Note the angle by which the steering wheel deviates from the desired straight-ahead position.

3 Raise the front of the vehicle by driving it onto ramps, or with a jack and axle stands.

4 Slacken both tie-rod end locknuts. Also slacken the steering rack bellows outer clips.

5 Make alignment marks between each tie-rod end and its rod, so that the amount of rotation applied can be accurately determined (see illustration).

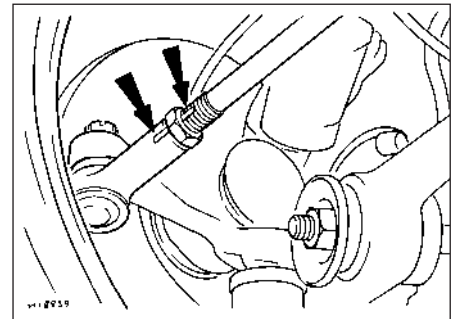

23.5 Make alignment marks (arrowed) between each tie-rod end and its rod when centralising the steering wheel



24.4a Remove the steering column upper shroud . . .

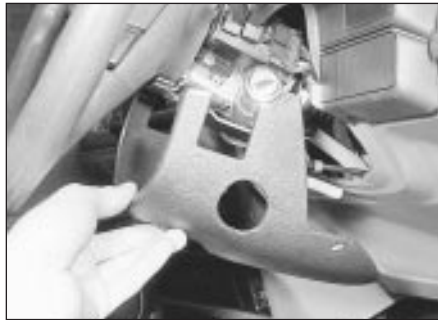

24.4b . . . and lower shroud

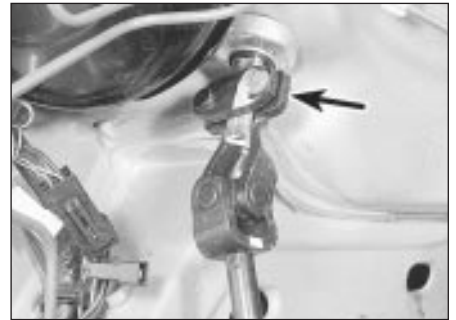

24.7 Intermediate shaft-to-inner column universal joint and clamp plate (arrowed)

- 6 Turn both tie-rods in the same direction to correct the steering wheel position. As a rough guide, 19° of tie-rod rotation will change the steering wheel position by 1°. To correct a clockwise error at the steering wheel, rotate both tie-rods anti-clockwise (when viewed from the left-hand side of the vehicle), and the reverse to correct an anti-clockwise error. Both tie-rods must be rotated by the same amount.
- 7 Tighten the bellows clips and the tie-rod end locknuts when adjustment is correct. Lower the vehicle.

24 Steering column - removal and refitting



Removal

- 1 Set the front wheels in the straight-ahead position.
- 2 Disconnect the battery negative lead.
- 3 Remove the driver's side lower facia trim panels.
- 4 Remove the screws and withdraw the steering column upper and lower shrouds (see illustrations).

- 5 Unscrew the two crosshead screws and withdraw the two combination switches from the column.
- 6 Remove the screw from the bonnet release lever and remove the lever.
- 7 Working in the engine compartment, unscrew the bolt securing the intermediate shaft to the inner column, swivel the clamp plate to one side, and disconnect the intermediate shaft (see illustration).
- 8 Unscrew the nuts securing the outer column to the facia.
- 9 Disconnect the multi-plugs and withdraw the column assembly upwards (see illustration).

Refitting

- 10 Refit the column assembly in the car and tighten the upper mounting nuts lightly. Loosen the mounting pinch-bolt.
- 11 Temporarily fit the upper column shroud and adjust the position of the steering column until there is a gap of 5.0 mm (0.2 in) between the shroud and the facia (see illustration).
- 12 Tighten the pinch-bolt and the mounting nuts and remove the upper column shroud.
- 13 With the steering wheel in the straight-ahead position, reconnect the

intermediate shaft and tighten the clamp plate bolt to the specified torque.

- 14 Refit the bonnet release lever and combination switches and reconnect the multi-plugs.
- 15 Refit the steering column shrouds and trim panels.
- 16 Reconnect the battery negative lead.

25 Steering column adjuster - dismantling and reassembly



Note: A new adjuster locknut and washer must be used on reassembly.

Dismantling

- 1 To dismantle the adjuster assembly, proceed as follows.
- 2 Remove the locknut and washer securing the adjuster through-bolt (see illustration).
- 3 Remove the through-bolt, adjuster handle, locking plates, sliders and washers, then unclip the spring assembly.

Reassembly

- 4 Reassemble the components as follows.
- 5 Refit the spring to the adjuster assembly bracket.

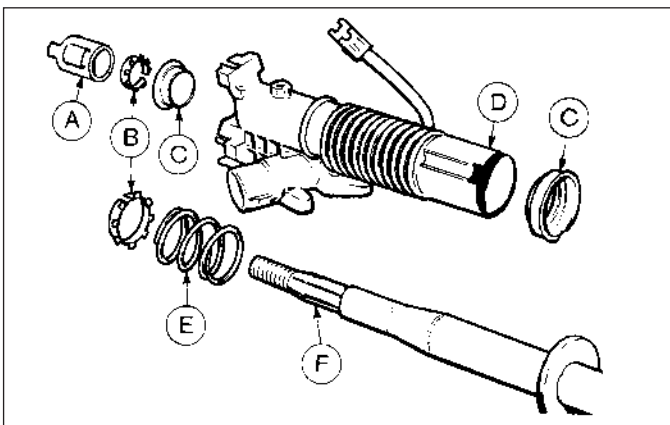

24.9 Steering column components

- | | |
|---------------------------|----------------|
| A Direction indicator cam | D Outer column |
| B Thrustwashers | E Spring |
| C Bearings | F Inner column |

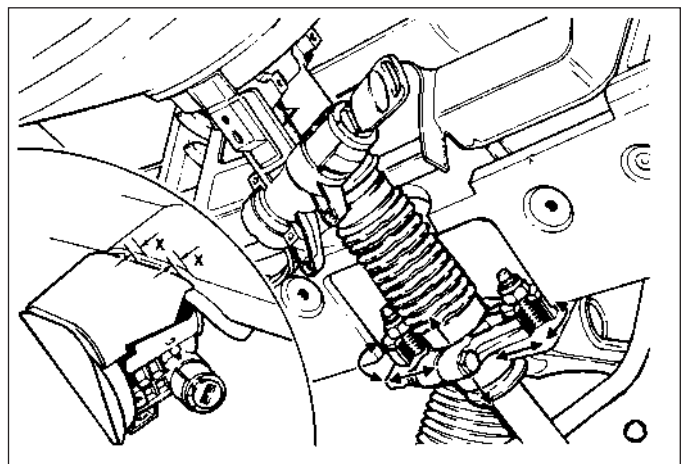

24.11 Upper column shroud-to-facia gap adjustment

X = 5.0 mm (0.2 in)

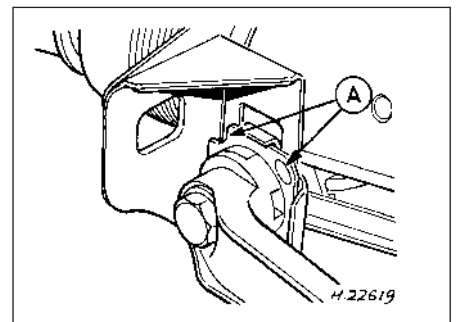
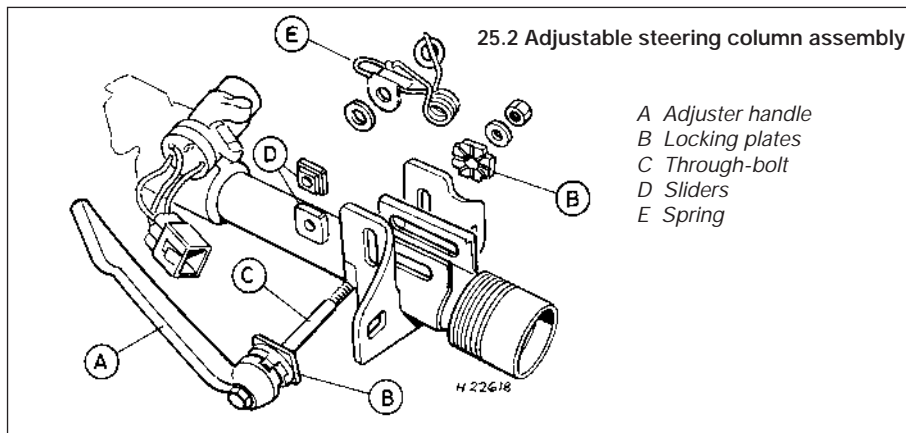

6 Align the washers, sliders and locking plates, ensuring that the handle locking plate is fitted so that the cut-out and Ford logo are positioned as shown (see illustration).

7 Coat the through-bolt threads with a suitable thread-locking compound, then refit the through-bolt and the adjuster handle, ensuring that all components are engaged.

8 Position the handle in the locked position, and secure the through-bolt with a new locknut and washer.

26 Steering intermediate shaft and flexible coupling - removal and refitting

Removal

1 Apply the handbrake, jack up the front of the vehicle and support on axle stands.

2 Working in the engine compartment, unscrew the bolt securing the intermediate shaft to the inner column, swivel the clamp plate to one side, and disconnect the intermediate shaft.

3 Unscrew and remove the clamp bolt securing the flexible coupling to the steering gear (see illustration).

4 Mark the coupling in relation to the pinion, then pull off the intermediate shaft and remove it from the vehicle. The pinion has a master spline, but making alignment marks will aid refitting (see illustration).



26.3 Intermediate shaft-to-steering gear flexible coupling

Refitting

5 Refitting is a reversal of removal, but align the marks on the coupling and pinion, and tighten all bolts to the specified torque.

27 Manual steering gear - removal and refitting

Note: A balljoint separator tool will be required for this operation.

Removal

1 Set the front wheels in the straight-ahead position. Ensure that the steering lock is engaged and remove the ignition key.

2 Apply the handbrake. Loosen the front roadwheel nuts, jack up the front of the vehicle and support on axle stands.

3 Remove the roadwheels. On P100 models, mark the position of the roadwheels in relation to the wheel studs.

4 Unscrew and remove the clamp bolts securing the intermediate shaft flexible coupling to the steering gear.

5 If the original steering gear is to be refitted, mark the coupling in relation to the pinion. The pinion has a master spline, but making alignment marks will aid refitting.

6 Slacken the tie-rod end locknuts (see illustration).

7 Remove the split pins and unscrew the castellated nuts from the tie-rod end-to-hub carrier balljoints.

8 Using a balljoint separator tool, disconnect the tie-rod ends from the hub carriers.

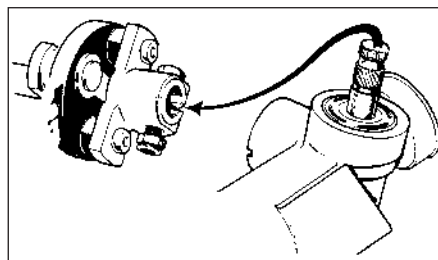

26.4 Master spline location on the steering gear pinion and intermediate shaft coupling

9 Unscrew the two steering gear-to-front suspension crossmember securing bolts, and withdraw the steering gear from under the vehicle.

10 If required, remove the tie-rod ends.

11 Refitting is a reversal of removal, bearing in mind the following points.

12 If new steering gear is being fitted, the central pinion position can be ascertained by halving the number of turns required to move the rack from lock to lock.

13 Where applicable, align the marks made on the coupling and pinion.

14 When tightening the steering gear-to-front suspension crossmember bolts, the following procedure should be used. Tighten the bolts to the specified "clamping" torque, then loosen the bolts fully. Re-tighten to the specified "snug" torque and then further tighten the bolts through the specified angle.

15 Tighten all fixings to the specified torque, and use new split pins on the balljoint castellated nuts.

16 On P100 models, align the previously made marks on the roadwheels and wheel studs.

17 On completion, check the front wheel alignment.

18 On completion, check the front wheel alignment.

19 On completion, check the front wheel alignment.

20 On completion, check the front wheel alignment.

21 On completion, check the front wheel alignment.

22 On completion, check the front wheel alignment.

23 On completion, check the front wheel alignment.

24 On completion, check the front wheel alignment.

25 On completion, check the front wheel alignment.

26 On completion, check the front wheel alignment.

27 On completion, check the front wheel alignment.

28 On completion, check the front wheel alignment.

29 On completion, check the front wheel alignment.

30 On completion, check the front wheel alignment.

31 On completion, check the front wheel alignment.

32 On completion, check the front wheel alignment.

28 Power steering gear - removal and refitting

Note: New power steering fluid hose O-rings will be required when refitting.

Removal

1 The procedure is as described for manual steering gear with the following differences (see illustration).

2 Before removing the steering gear from the suspension crossmember, place a suitable container beneath the steering gear. Unscrew the single bolt securing the power steering fluid hoses to the pinion housing. Unscrew the hose unions and drain the power steering fluid. Plug the ends of the hoses and the steering gear apertures, or cover them with masking tape to prevent dirt ingress.

27.6 Manual steering gear components

- A Pinion retaining nut
- B Pinion
- C Steering gear housing
- D Rack support bush
- E Tie-rod
- F Gaiter
- G Slipper plug
- H Spring
- J Slipper

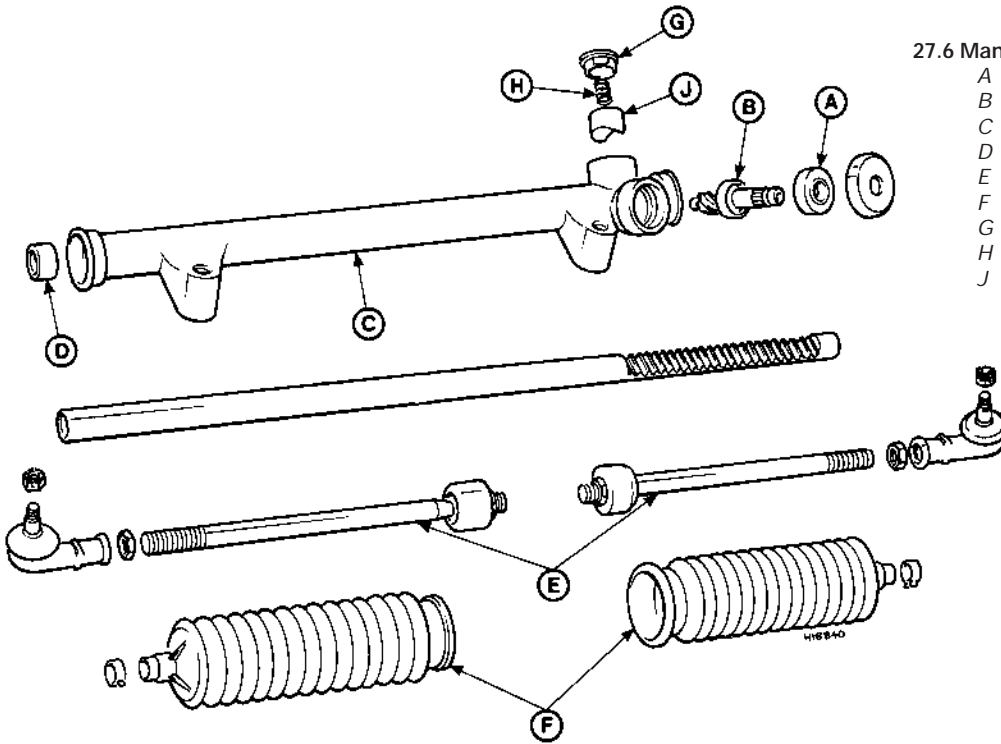

28.1 Power steering gear components

- A Pinion locknut assembly
- B Pinion
- C Pinion upper bearing and seal
- D Slipper assembly
- E Pinion lower bearing assembly
- F Rack
- G Tie-rod
- H Tie-rod end
- J Gaiter
- K Rack support bearing and seal
- L Inner rack seal and support bearing
- M Rack support bearing locking wire
- N Steering gear housing

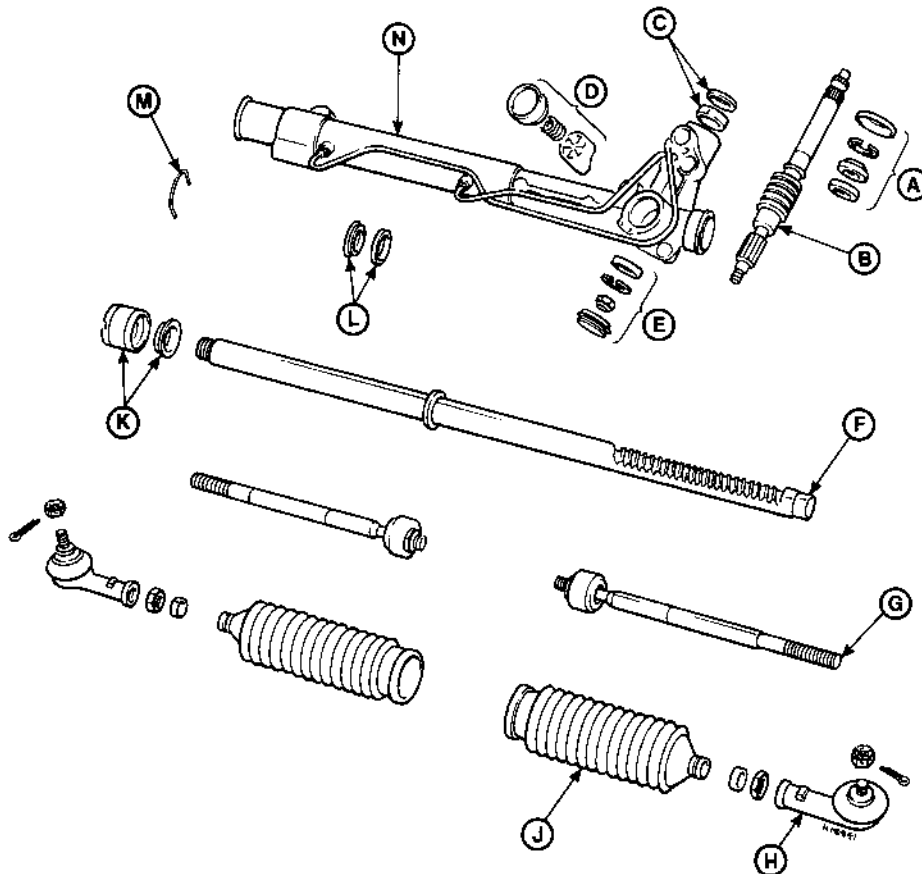

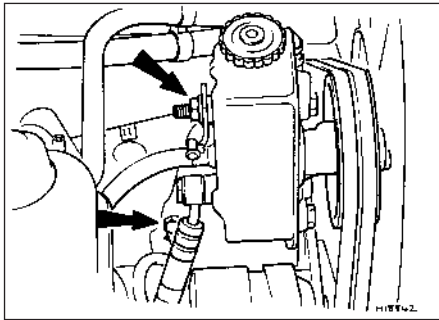

29.3 Power steering pump rear support bar bolts (arrowed)

Refitting

3 When refitting the fluid hoses, use new O-rings, and take care not to overtighten the unions. Note that with the unions fully tightened it is still possible to rotate and move the hoses.

4 On completion of refitting, bleed the power steering fluid circuit (Section 34).

29 Power steering pump - removal and refitting

Note: New power steering fluid hose O-rings will be required when refitting.

All engines except 1.8 litre (R6A) CVH and 2.0 litre DOHC

1 Place a suitable container under the power steering pump, unscrew the fluid hose unions, and drain the fluid. Ensure that fluid is not allowed to spill onto the alternator.

2 Remove the drivebelts and unbolt the power steering pump pulley if necessary to ease removal.

3 Unbolt the rear support bar from the pump and the engine block (see illustration).

4 Unbolt the pump from its mounting bracket, and withdraw the pump from the engine.

5 Refitting is a reversal of removal, noting the following points.

6 Tension the drivebelts correctly.

7 When refitting the fluid hoses, use new O-rings, and take care not to overtighten the unions.



29.14a Unbolt the power steering pump pulley for access to the front pump securing bolts (arrowed)

8 On completion of refitting, bleed the power steering fluid circuit.

1.8 litre (R6A) CVH engine

9 The removal and refitting procedures are basically the same as described below for the 2.0 litre DOHC engine, except that the pump is mounted on a bracket above the alternator on the front left-hand side of the engine.

2.0 litre DOHC engine

10 The pump is mounted on a bracket on the front right-hand side of the cylinder block.

11 Place a suitable container under the pump, unscrew the fluid pipe unions, and drain the fluid.

12 Remove the drivebelt which also drives the coolant pump and alternator.

13 Prevent the pulley from rotating using a strap wrench (which can be improvised using an old drivebelt and a large socket and wrench), and unscrew the three pulley securing bolts. Withdraw the pulley.

14 Unscrew the three pump securing bolts from the front of the pump bracket, and the single bolt from the rear of the bracket, and withdraw the pump (see illustrations).

15 Refitting is a reversal of removal, bearing in mind the following points.

16 Reconnect the fluid unions using new O-rings.

17 On completion, bleed the power steering fluid circuit.

30 Power steering fluid hoses - removal and refitting

Note: New fluid hose O-rings will be required when refitting.

Removal

1 Clean around the hose unions on the steering gear. Place a suitable container beneath the steering gear, then remove the single bolt securing the hoses to the pinion housing, unscrew the hose unions and drain the power steering fluid.

2 Clean around the hose unions on the pump. Place a suitable container beneath the pump, unscrew the hose unions, and drain any remaining fluid. Ensure that no fluid is allowed to spill onto the alternator.



29.14b Power steering pump rear securing bolt

3 If the hoses are to be left disconnected for a long period of time, plug the ends of the hoses and the apertures in the steering gear and pump, or cover them with masking tape to prevent dirt ingress.

Refitting

4 Refit in reverse order using new O-rings.

5 On completion top-up the fluid and bleed the system.

31 Power steering fluid circuit - bleeding

1 Unscrew the filler cap from the power steering pump reservoir and top-up the fluid level to the maximum mark using the specified fluid.

2 Disconnect the low tension negative lead from the ignition coil and crank the engine several times for two second periods while slowly turning the steering wheel from lock-to-lock. Top-up the fluid level if necessary and continue cranking the engine until the fluid is free of air bubbles.

3 Reconnect the coil lead and start the engine. Check the system for leaks.

4 Switch off the engine and refit the filler cap.

5 Drive the vehicle for a few miles to warm up the fluid and expel any remaining air, then stop the engine and make a final fluid level check.

32 Steering gear rubber gaiter - renewal

1 Remove the tie-rod end.

2 Unscrew and remove the tie-rod end locknut from the tie-rod.

3 Remove the clips and slide the gaiter from the tie-rod and steering gear.

4 Slide the new gaiter over the tie-rod and onto the steering gear. Where applicable, make sure that the gaiter seats in the cut-outs in the tie-rod and steering gear.

5 Secure the gaiter with new clips.

6 Refit the tie-rod end locknut to the tie-rod.

7 Refit the tie-rod end.

33 Tie-rod end - removal and refitting

Note: A balljoint separator tool will be required for this operation.

Removal

1 Loosen the relevant front roadwheel nuts, apply the handbrake, jack up the front of the vehicle and support on axle stands.

2 Remove the roadwheel. On P100 models mark the position of the roadwheel in relation to one of the wheel studs before removal.

3 Make alignment marks on the tie-rod and tie-rod end, then loosen the locknut by a quarter of a turn.



33.4 Extracting the split pin from the tie-rod balljoint castellated nut

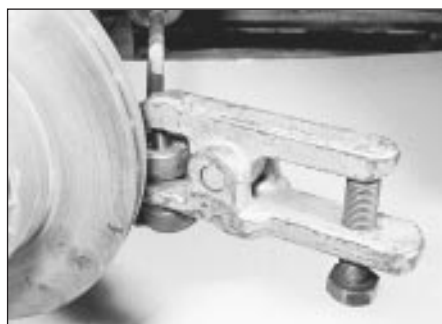

33.5 Using a balljoint separator tool to release the tie-rod end from the hub carrier

- 4 Extract the split pin and unscrew the castellated nut (see illustration).
- 5 Using a balljoint separator tool, release the tie-rod end from the hub carrier (see illustration).
- 6 Unscrew the tie-rod end from the tie-rod, noting the number of turns necessary to remove it.

Refitting

- 7 Refitting is a reversal of removal, bearing in mind the following points.
- 8 Screw the tie-rod end onto the tie-rod the number of turns noted during removal.
- 9 Tighten the nuts to the specified torque, and fit a new split pin to the castellated nut.
- 10 On P100 models, align the previously made marks on the roadwheel and wheel stud.
- 11 On completion, check and if necessary adjust the front wheel alignment.

34 Front wheel alignment - checking and adjusting



- 1 Front wheel alignment is defined by camber, castor steering axis inclination and toe setting. The first three factors are determined in production; only toe can be adjusted in service. Incorrect toe will cause rapid tyre wear.
- 2 Toe is defined as the amount by which the distance between the front wheels, measured at hub height, differs from the front edges to

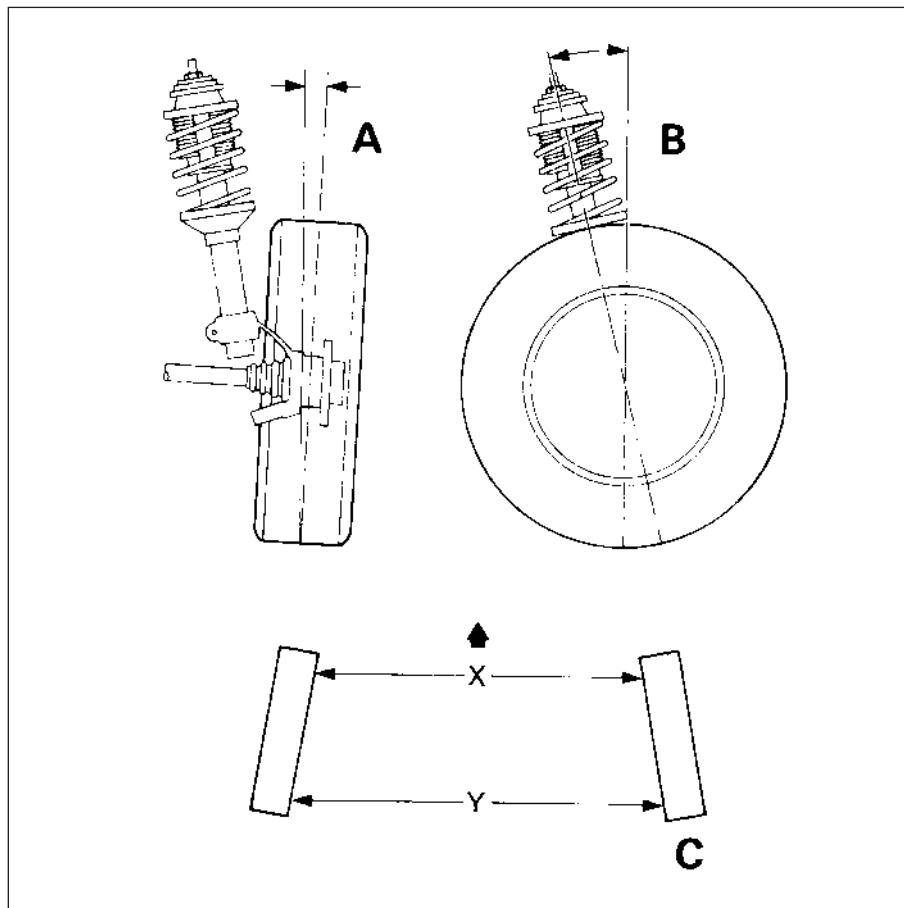

34.6 Front wheel alignment

A Camber

B Castor

C Toe setting

For X and Y, see text

the rear edges. If the distance between the front edges is less than that at the rear, the wheels are said to toe-in; the opposite case is known as toe-out.

- 3 To measure toe, it will be necessary to obtain or make a tracking gauge. These are available in motor accessory shops, or one can be made from a length of rigid pipe or bar with some kind of threaded adjustment facility at one end. Many tyre specialists will also check toe free, or for a nominal sum.

- 4 Before measuring toe, check that all steering and suspension components are undamaged and that tyre pressures are correct. The vehicle must be at approximately kerb weight, with the spare wheel and jack in their normal positions and any abnormal loads removed.

- 5 Park the vehicle on level ground and bounce it a few times to settle the suspension.
- 6 Use the tracking gauge to measure the distance between the inside faces of the front wheel rims, at hub height, at the rear of the front wheels. Record this distance; call it measurement "Y" (see illustration).

- 7 Push the vehicle forwards or backwards so that the wheels rotate exactly 180° (half a turn). Measure the distance between the front wheel rims again, this time at the front of the wheels. Record this distance; call it measurement "X".

- 8 Subtract measurement "X" from measurement "Y". If the answer is positive it is the amount of toe-in; if negative it is the amount of toe-out. Permissible values are given in the Specifications.

- 9 If adjustment is necessary loosen the tie-rod end locknuts and the outer bellows clips, then rotate each tie-rod by equal amounts until the setting is correct. Hold the tie-rod ends in their horizontal position with a spanner while making the adjustment.

- 10 Tighten the locknuts and outer bellows clips.

- 11 Provided the tie-rods have been adjusted by equal amounts the steering wheel should be central when moving straight-ahead. The amount of visible thread on each tie-rod should also be equal. If necessary refer to Section 23.

